

SLIDE TABLE

The NB slide table is a precision table equipped with a slide way. Its high-precision and low-friction characteristics make it well suited for use in electronics automatic-assembly machines, optical measurement devices, etc.

STRUCTURE AND ADVANTAGES

The NB slide table consists of a slide way sandwiched between an accurately machined table and a bed. Stoppers are provided inside the table.

High Accuracy

The mounting surfaces of the table and bed are precision finished to ensure high precision linear motion, resulting in a high performance slide way.

Low Friction

Its non-recirculating mechanism provides stable motion at from low to high speeds.

Compact and High Rigidity

Being designed compactly, the NB slide table holds the high load capacity and high rigidity characteristics.

No Need for Adjustment

The table is carefully assembled so that the accuracy and preload are optimized, it can be used immediately without any further adjustment.

Ease of Mounting

Standardized mounting holes are provided in the table and bed. High precision linear motion can be achieved simply by mounting.

Figure G-16 Structure of NVT type

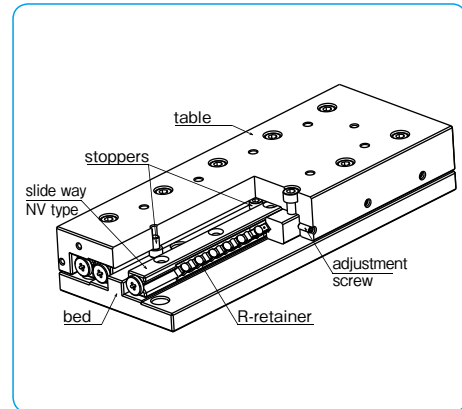
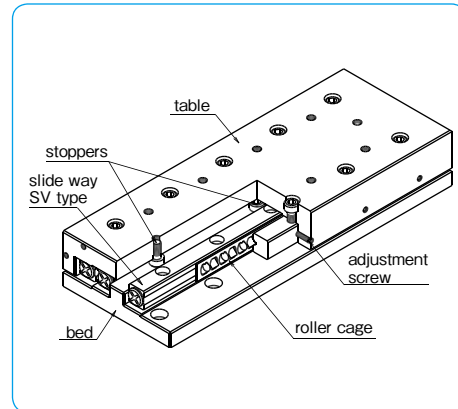
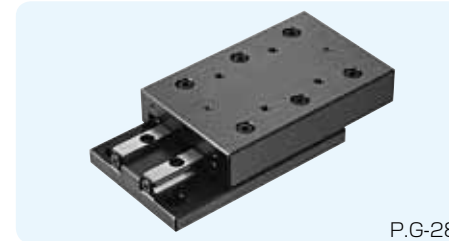

Figure G-17 Structure of SVT type



TYPES

NVT·NVTS type



P.G-28

The NVT type slide table incorporates the NV type slide way. The table and bed have been precision machined to provide a high degree of accuracy and the product can be used, without any need for troublesome accuracy or preload adjustments. In the NVTS type, the anti-corrosion NVS type slide way is sandwiched between an accurately machined aluminum table and bed.

SVT·SVTS type

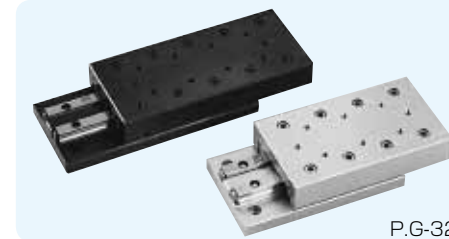

P.G-32

In the SVT type slide table, the SV type slide way is sandwiched between an accurately machined steel table and bed. In the SVTS type, the anti-corrosion SVS type slide way is sandwiched between an accurately machined aluminum table and bed.

SYT·SYTS type

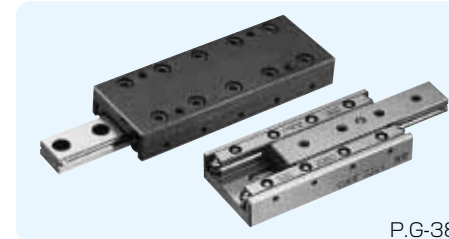

P.G-38

The SYT/SYTS type is a thin, compact slide table. Either tapped or counterbore type (D type) is available for the mounting hole. The anti-corrosion SYTS type slide table is made of all stainless steel components, making it suitable for use in clean rooms.

ACCURACY

The motion accuracy of a slide table is measured by placing indicators at the center of the top and side surface of the table, as illustrated in Figure G-18. It is expressed in terms of the indicator deviation when the table is moved the full stroke without any load.

Figure G-18 Accuracy Measurement Method

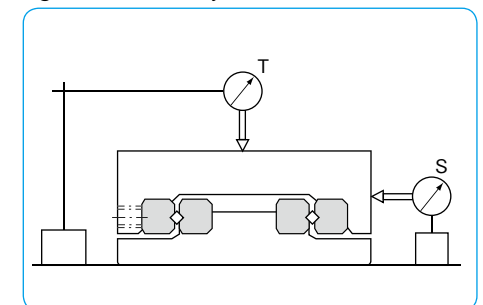

RATED LIFE

The life of an NB slide table is calculated using the following equations.

Rated Life

$$L = \left(\frac{f_r \cdot C}{f_w \cdot P} \right)^{10/3} \cdot 50$$

L: rated life(km) f_r: temperature coefficient f_w: applied load coefficient
 C: basic dynamic load rating(N) P: applied load(N)
 ※Please refer to page Eng-5 for the coefficients.

Life Time

$$L_h = \frac{L \cdot 10^3}{2 \cdot l_s \cdot n \cdot 60}$$

L_h: life time (hr) l_s: stroke length (m)
 n: number of cycles per minute (cpm)

LOAD RATING

The load rating of the slide table NVT type differs depending on the direction of the load.

Table G-6 Change of Load Rating Corresponding to Load Direction

basic dynamic load rating	normal vertical direction	1.0×C
	horizontal direction	0.85×C
	reverse vertical direction	0.7×C
basic static load rating	normal vertical direction	1.0×C ₀
	horizontal direction	0.85×C ₀
	reverse vertical direction	0.7×C ₀

※There may be a difference depending on the size. Please contact NB for details.
 Consideration has been given to holes for STUDROLLERS in the raceway surface in calculation of load ratings.

Figure G-19 Direction of Load

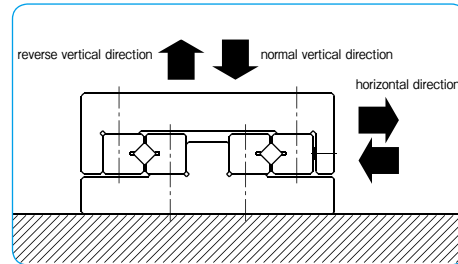

USE AND HANDLING PRECAUTIONS

Careful Handling

Dropping the slide table causes the rolling elements to make dents in the raceway surface. This will prevent smooth motion and will also affect accuracy. Be sure to handle the product with care.

Dust Prevention

Dust and foreign particles affect the accuracy and lifetime of a slide table. A slide table used in a harsh environment should be protected with a cover.

Lubrication

The slide table is prelubricated with lithium soap based grease prior to shipment for immediate use. Make sure to relubricate with a similar type of grease periodically depending on the operating conditions.

Cage Slippage

For the SVT/SYT type, the cage can slip under high-speed motion, vertical application, unbalanced-loading, and vibrating conditions. It is advised

that the motion speed be kept under 30m/min under general operating conditions. It is also recommended that the rails be cycled to perform the maximum stroke several times, so that the cage returns to its central position.

Adjustment/Installation Screw

The NB slide table is adjusted to achieve optimum accuracy and preload. The adjustment screw and rail installation screws should be kept untouched.

Allowable Load

The allowable load is a load under which the sum of elastic deformations of the rolling element and the raceway in the contact area subject to the maximum contact stress is small enough to guarantee smooth rolling movement. When very smooth and highly accurate linear motion is required, make sure to use the product within the allowable load.

SPECIAL REQUIREMENTS

NB can machine tables to meet special requirements, including tables with a micrometer head and tables for projectors. Please contact NB for details.

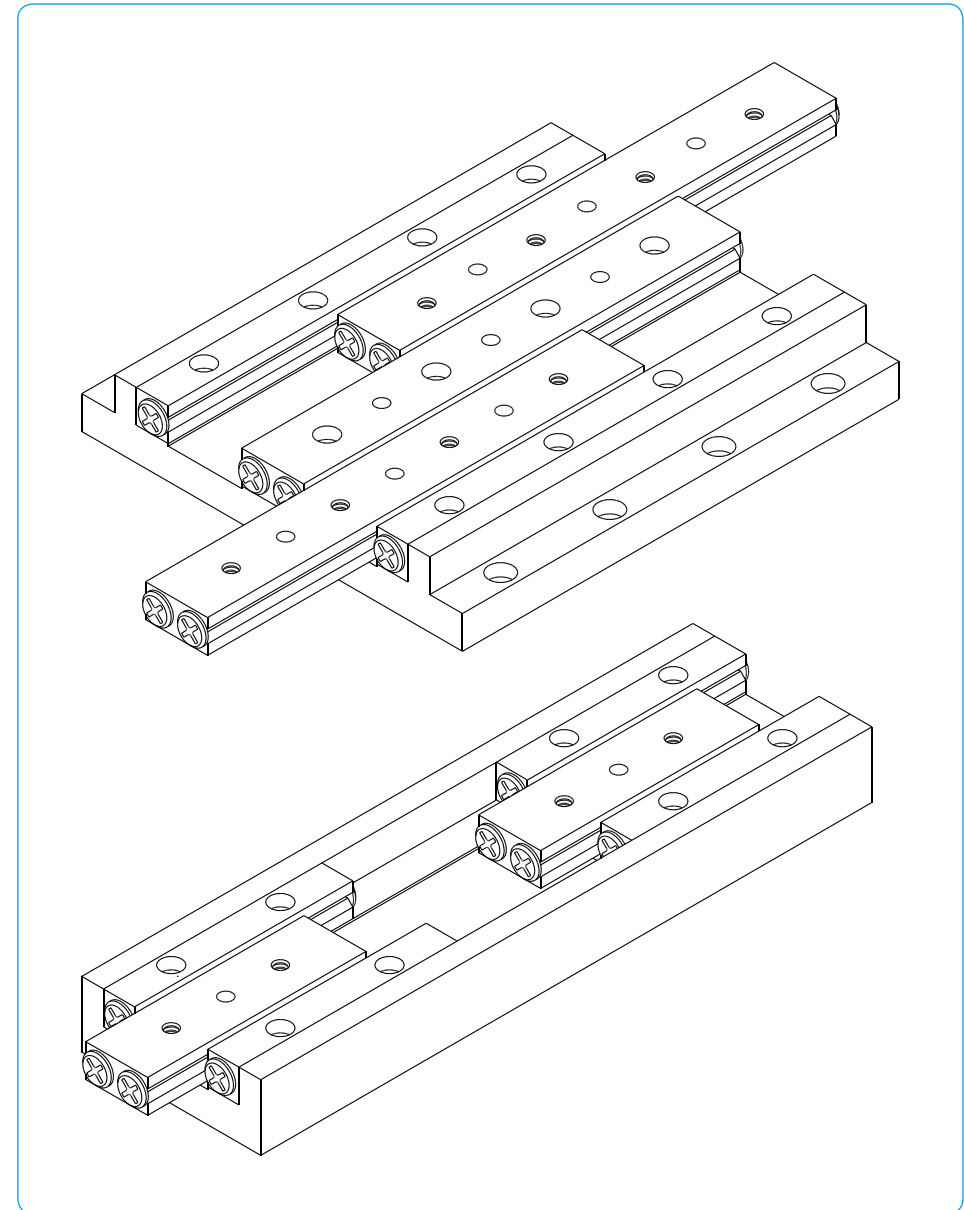

NVT TYPE

-NVT2/NVT3/NVT4-

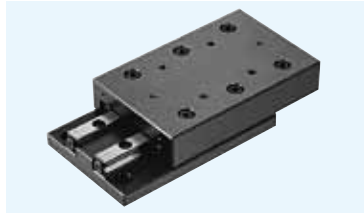

part number structure

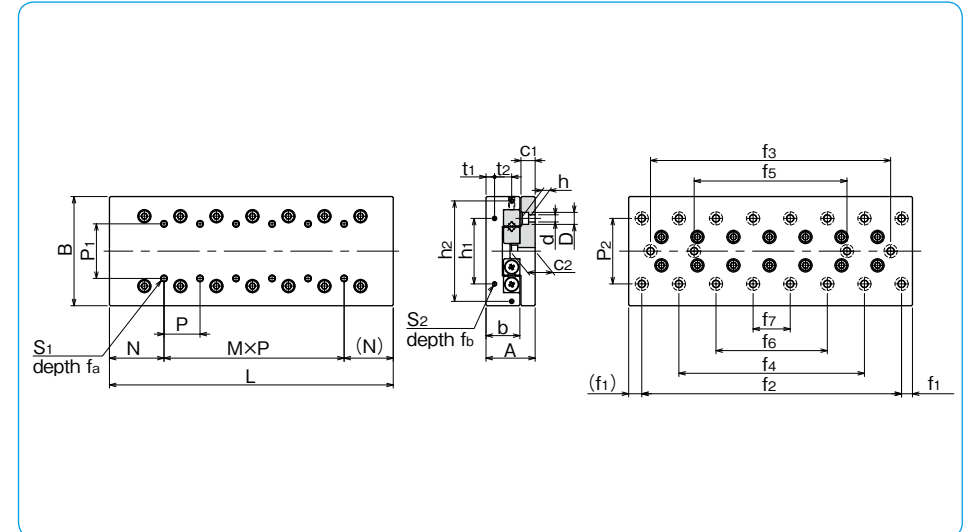
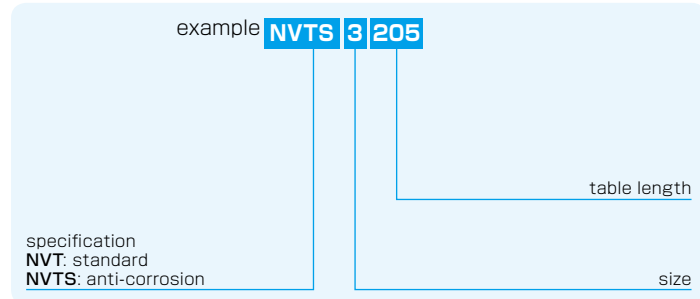

part number		stroke	major dimensions				table-top mounting hole dimensions				table-end mounting hole dimensions						
standard	anti-corrosion	ST mm	A mm	B mm	L mm	b mm	P ₁ mm	S ₁	f _a mm	N mm	M×P mm	h ₁ mm	h ₂ mm	t ₁ mm	t ₂ mm	S ₂	f _b mm
NVT2035	NVTS2035	18			35						—						
2050	2050	30			50					1×15							
2065	2065	40			65					2×15							
2080	2080	50			80					3×15							
2095	2095	60			95					4×15							
2110	2110	70	21 ^{±0.1}	40 ^{-0.2/-0.4}	110	14	15	M3	6	17.5	5×15	16	—	3.4	—	M2	6
2125	2125	80			125					6×15							
2140	2140	90			140					7×15							
2155	2155	100			155					8×15							
2170	2170	110			170					9×15							
2185	2185	120			185					10×15							
NVT3055	NVTS3055	30			55					—							
3080	3080	45			80					1×25							
3105	3105	60			105					2×25							
3130	3130	75			130					3×25							
3155	3155	90	28 ^{±0.1}	60 ^{±0.1}	155	18.5	25	M4	8	27.5	4×25	40	—	5.5	—	M3	6
3180	3180	105			180					5×25							
3205	3205	130			205					6×25							
3230	3230	155			230					7×25							
NVT4085	NVTS4085	50			85					—							
4125	4125	75			125					1×40							
4165	4165	105	35 ^{±0.1}	80 ^{±0.1}	165	24	40	M5	10	42.5	2×40	55	—	6.5	—	M3	6
4205	4205	130			205					3×40							
4245	4245	155			245					4×40							
4285	4285	185			285					5×40							

The basic static load rating is the value at the center of the stroke.

bed-surface mounting hole dimensions											accuracy ※(deviation)		basic load rating		allowable load		allowable static moment			mass	size	
P ₂ mm	d×D×h mm	c ₁ mm	c ₂ mm	f ₁ mm	f ₂ mm	f ₃ mm	f ₄ mm	f ₅ mm	f ₆ mm	f ₇ mm	T μm	S μm	C N	Co N	F N	M _P N·m	M _Y N·m	M _R N·m	g			
30	3.5×6.5×3.5	6.5	10.9	5	25	—	—	—	—	—	2	4	1,360	1,520	509	10.1	8.8	13.7	200	2035		
					40	—	—	—	—	—	—	—	2	4	2,330	3,050	1,010	18.9	18.7	21.1	287	2050
					55	—	—	—	—	—	2	5	3,190	4,580	1,520	36.9	35.7	34.8	377	2065		
					70	—	40	—	—	—	2	5	3,990	6,110	2,030	53.2	53.8	39.8	455	2080		
					85	—	55	—	—	—	2	5	4,740	7,630	2,540	80.3	79.9	53.5	550	2095		
					100	—	70	—	—	—	3	6	5,460	9,160	3,050	104	106	58.4	640	2110		
					115	—	85	—	—	—	3	6	6,160	10,600	3,560	130	135	63.4	730	2125		
					130	—	100	—	70	—	3	6	6,830	12,200	4,070	171	176	77.1	810	2140		
					145	—	115	—	85	—	3	6	8,130	15,200	5,090	235	244	90.9	890	2155		
					160	—	130	—	100	—	3	7	8,750	16,800	5,600	275	289	95.8	980	2170		
175	—	145	—	115	85	3	7	9,370	18,300	6,110	317	338	100	1,070	2185							
40	4.5×8×4.5	9	15	10	35	—	—	—	—	—	2	5	6,150	8,060	2,680	23.6	37.2	41	643	3055		
					60	—	—	—	—	—	2	5	8,440	12,100	4,030	125	119	154	960	3080		
					85	—	—	—	—	—	3	6	10,500	16,100	5,370	188	186	181	1,260	3105		
					110	—	—	—	—	—	3	6	14,400	24,200	8,060	302	319	208	1,580	3130		
					135	85	—	—	—	—	3	6	16,300	28,200	9,410	508	505	321	1,860	3155		
					160	110	—	—	—	—	3	7	18,100	32,200	10,700	630	635	349	2,160	3180		
					185	135	85	—	—	—	3	7	19,800	36,300	12,100	763	779	376	2,460	3205		
					210	160	110	—	—	—	3	7	21,500	40,300	13,400	907	936	403	2,780	3230		
					235	—	—	—	—	—	2	5	12,100	15,700	5,250	156	147	279	1,710	4085		
					265	185	—	—	—	—	3	7	42,400	78,700	26,200	2,380	2,400	1,230	5,730	4285		

※For accuracy (T, S), refer to Figure G-18 (page G-25).

1N≒0.102kgf 1N·m≒0.102kgf·m

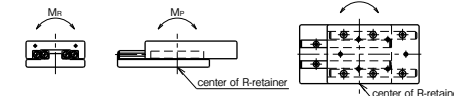

NVT TYPE

-NVT6/NVT9-

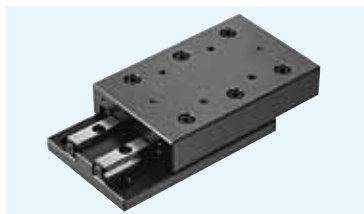

part number structure

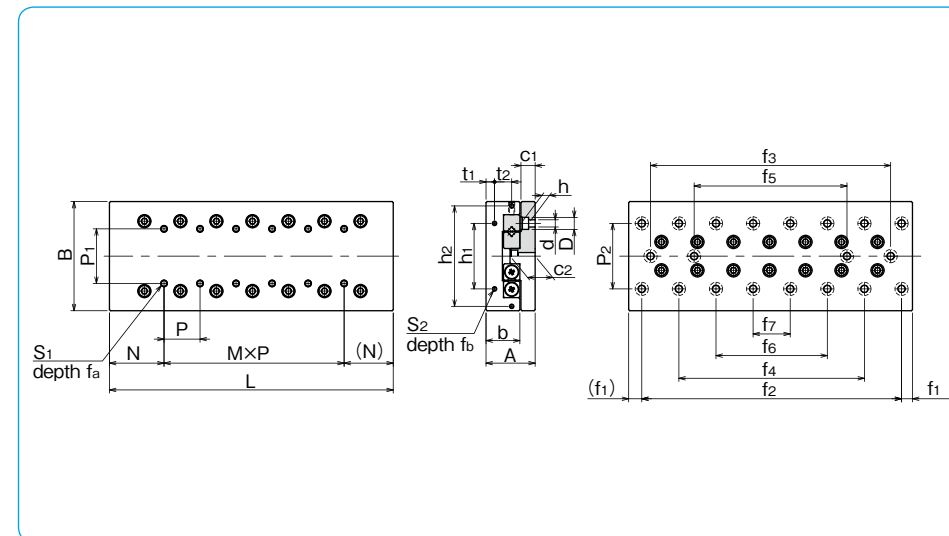
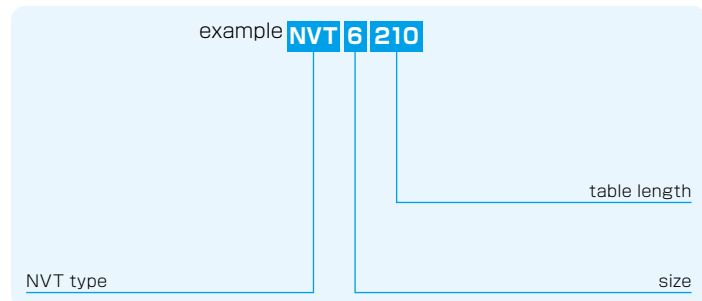

part number	stroke	major dimensions					table-top mounting hole dimensions					table-end mounting hole dimensions						d×D×h mm
	ST mm	A mm	B mm	L mm	b mm	P ₁ mm	S ₁ mm	f _a mm	N mm	M×P mm	h ₁ mm	h ₂ mm	t ₁ mm	t ₂ mm	S ₂ mm	f _b mm	P ₂ mm	
NVT6110	60			110						—								
6160	95			160					1×50									
6210	130			210					2×50									
6260	165	45±0.1	100±0.1	260	31	50	M6	12	55	3×50	60	92	8	15	M4	8	60	7×11.5×7
6310	200			310						4×50								
6360	235			360						5×50								
6410	265			410						6×50								
NVT9210	130			210						—								
9310	180	60±0.1	145±0.1	310	43	85	M8	16	105	1×100	90	135	11	20	M4	8	90	9×14×9
9410	220			410						2×100								
9510	300			510						3×100								

The basic static load rating is the value at the center of the stroke.

bed-surface mounting hole dimensions										accuracy ※(deviation)		basic load rating		allowable load	allowable static moment			mass	size
c ₁ mm	c ₂ mm	f ₁ mm	f ₂ mm	f ₃ mm	f ₄ mm	f ₅ mm	f ₆ mm	f ₇ mm	T μm	S μm	C N	Co N	F N	M _P N·m	M _Y N·m	M _R N·m	g		
13	23	10	90	—	—	—	—	—	3	6	29,600	37,500	12,500	216	303	343	3,300	6110	
			140	—	—	—	—	—	3	6	40,700	56,300	18,700	937	927	995	4,850	6160	
			190	90	—	—	—	—	—	3	7	60,600	93,900	31,300	1,950	1,980	1,410	6,310	6210
			240	140	—	—	—	—	—	3	7	69,800	112,000	37,500	2,680	2,770	1,640	7,790	6260
			290	190	—	—	—	—	—	3	7	78,800	131,000	43,800	4,460	4,410	2,490	9,260	6310
			340	240	140	—	—	—	—	4	8	87,400	150,000	50,100	5,570	5,580	2,720	10,900	6360
16	29	55	390	290	190	—	—	—	4	8	104,000	187,000	62,600	7,440	7,660	2,950	12,460	6410	
			100	—	—	—	—	—	—	3	6	96,100	128,000	42,600	1,700	2,110	2,260	12,550	9210
			200	—	—	—	—	—	—	3	6	143,000	213,000	71,100	6,550	6,580	5,330	18,000	9310
			300	100	—	—	—	—	—	3	7	186,000	298,000	99,500	12,600	12,700	7,770	24,010	9410
			400	200	—	—	—	—	—	3	7	206,000	341,000	113,000	18,700	18,600	10,200	30,100	9510

※For accuracy (T, S), refer to Figure G-18 (page G-25).

1N ≅ 0.102kgf 1N · m ≅ 0.102kgf · m

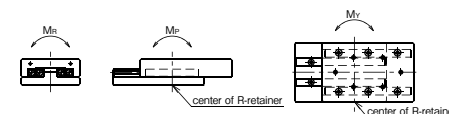

SVT TYPE

-SVT1/SVT2-

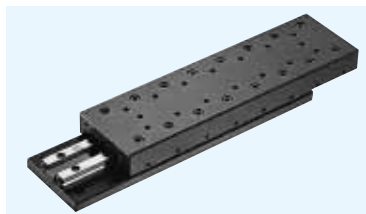

part number structure

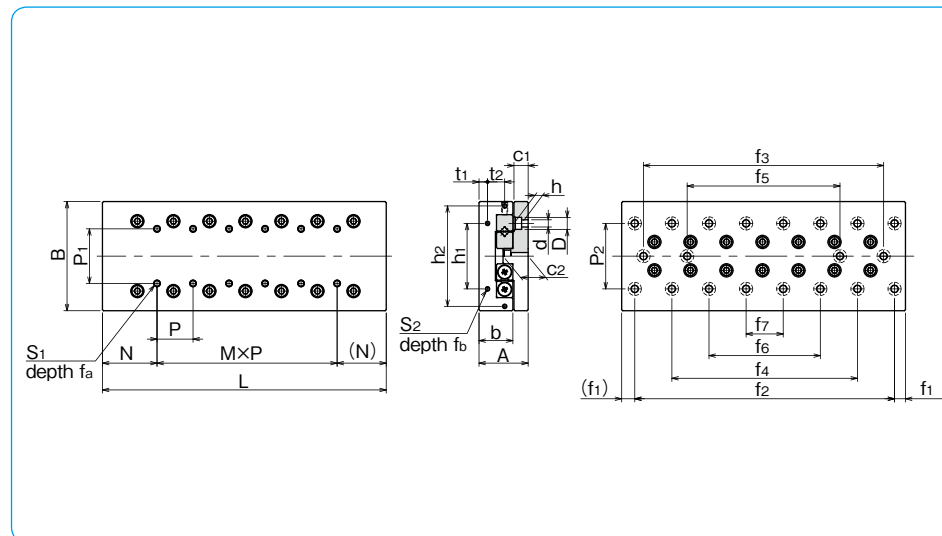
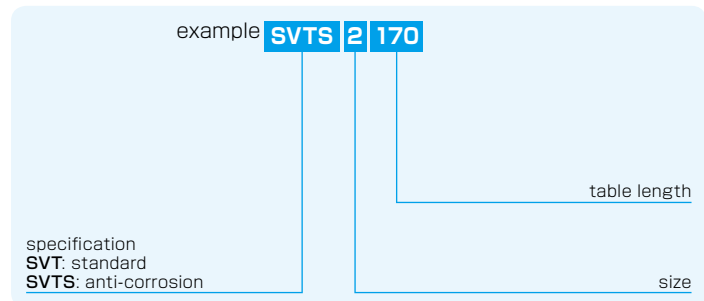

part number		stroke	major dimensions				table-top mounting hole dimensions					table-end mounting hole dimensions					
standard	anti-corrosion	ST mm	A mm	B mm	L mm	b mm	P ₁ mm	S ₁	f _a mm	N mm	M×P mm	h ₁ mm	h ₂ mm	t ₁ mm	t ₂ mm	S ₂	f _b mm
SVT 1025	SVTS 1025	12			25						—						
1035	1035	18			35					1×10							
1045	1045	25			45					2×10							
1055	1055	32	17 ^{±0.1}	30 ^{-0.4}	55	11	10	M2	4	12.5	3×10	12	—	2.5	—	M2	6
1065	1065	40			65						4×10						
1075	1075	45			75						5×10						
1085	1085	50			85						6×10						
SVT 2035	SVTS 2035	18			35						—						
2050	2050	30			50						1×15						
2065	2065	40			65						2×15						
2080	2080	50			80						3×15						
2095	2095	60			95						4×15						
2110	2110	70	21 ^{±0.1}	40 ^{-0.4}	110	14	15	M3	6	17.5	5×15	16	—	3.4	—	M2	6
2125	2125	80			125						6×15						
2140	2140	90			140						7×15						
2155	2155	100			155						8×15						
2170	2170	110			170						9×15						
2185	2185	120			185						10×15						

bed-surface mounting hole dimensions											accuracy ※(deviation)		basic load rating		allowable load		allowable static moment			mass		size
P ₂ mm	d×D×h mm	c ₁ mm	c ₂ mm	f ₁ mm	f ₂ mm	f ₃ mm	f ₄ mm	f ₅ mm	f ₆ mm	f ₇ mm	T μm	S μm	C N	Co N	F N	M _P N·m	M _Y N·m	M _R N·m	SVT g	SVTS g		
22	2.5×4.5×2.5	5.5	9	3.5	18	—	—	—	—	—	2	4	464	476	158	1.79	1.47	3.22	82	36	1025	
					28	—	—	—	—	—	2	4	805	952	316	3.08	3.5	6.45	120	50	1035	
					38	—	—	—	—	—	2	4	959	1,190	396	6.98	6.4	8.06	158	69	1045	
					48	—	28	—	—	—	2	5	1,100	1,420	475	9.53	8.81	9.68	190	83	1055	
					58	—	38	—	—	—	2	5	1,240	1,660	554	12.4	11.6	11.2	225	98	1065	
					68	—	48	—	—	—	2	5	1,510	2,140	712	19.3	18.3	14.5	260	113	1075	
					78	—	58	—	—	—	2	5	1,650	2,380	792	23.4	22.3	16.1	295	128	1085	
30	3.5×6.5×3.5	6.5	10.9	5	25	—	—	—	—	—	2	4	1,090	1,170	390	7.04	5.78	10.5	195	90	2035	
					40	—	—	—	—	—	2	4	1,510	1,750	585	12.1	10.7	15.8	280	133	2050	
					55	—	—	—	—	—	2	5	1,900	2,340	780	19.1	17.1	21.1	370	175	2065	
					70	—	40	—	—	—	2	5	2,620	3,510	1,170	27.4	29.6	31.6	450	220	2080	
					85	—	55	—	—	—	2	5	2,950	4,100	1,360	37.4	39.9	36.9	540	250	2095	
					100	—	70	—	—	—	3	6	3,280	4,680	1,560	61.7	58.1	42.2	630	285	2110	
					115	—	85	—	—	—	3	6	3,590	5,270	1,750	76.1	72.1	47.5	720	330	2125	
					130	—	100	—	70	—	3	6	4,210	6,440	2,140	92	95.9	58.1	800	360	2140	
					145	—	115	—	85	—	3	6	4,500	7,030	2,340	109	113	63.3	880	400	2155	
					160	—	130	—	100	—	3	7	4,790	7,610	2,530	148	143	68.6	970	440	2170	
					175	—	145	—	115	85	3	7	5,080	8,200	2,730	170	164	73.9	1,060	480	2185	

※For accuracy (T, S), refer to Figure G-18 (page G-25).

1N ≒ 0.102kgf 1N·m ≒ 0.102kgf·m

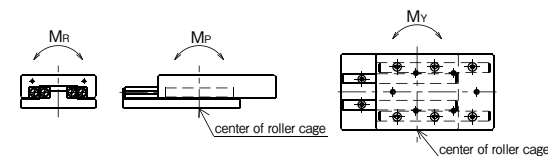

SVT TYPE

-SVT3/SVT4-

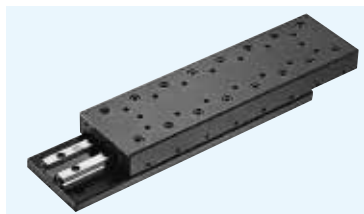

part number structure

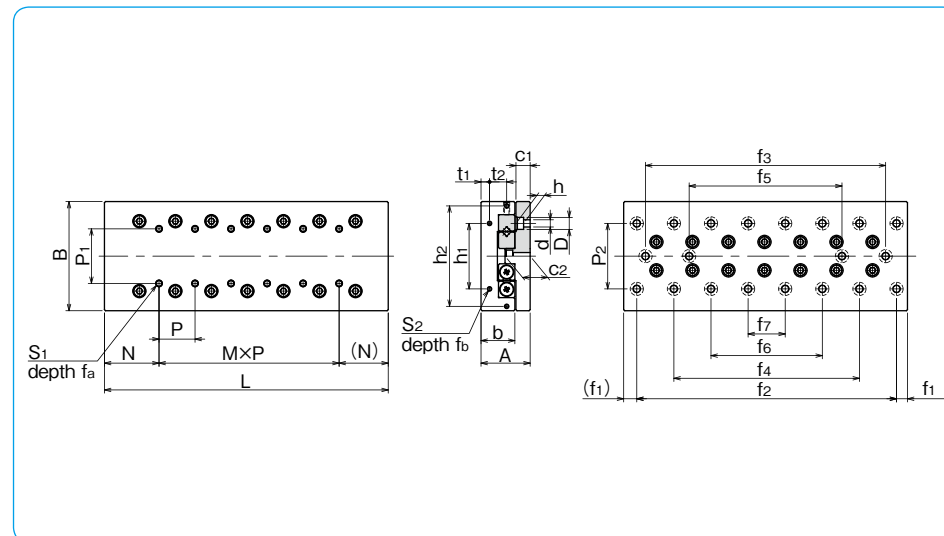
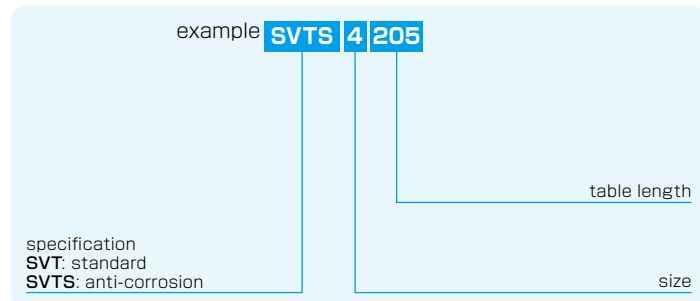

part number		stroke	major dimensions				table-top mounting hole dimensions				table-end mounting hole dimensions						
standard	anti-corrosion	ST mm	A mm	B mm	L mm	b mm	P ₁ mm	S ₁	f _a mm	N mm	M×P mm	h ₁ mm	h ₂ mm	t ₁ mm	t ₂ mm	S ₂	f _b mm
SVT 3055	SVTS 3055	30			55						—						
3080	3080	45			80					1×25							
3105	3105	60			105					2×25							
3130	3130	75			130					3×25							
3155	3155	90	28 ^{±0.1}	60 ^{±0.1}	155	18.5	25	M4	8	27.5	4×25	40	—	5.5	—	M3	6
3180	3180	105			180					5×25							
3205	3205	130			205					6×25							
3230	3230	155			230					7×25							
3255	3255	180			255					8×25							
3280	3280	205			280					9×25							
3305	3305	230			305					10×25							
SVT 4085	SVTS 4085	50			85					—							
4125	4125	75			125					1×40							
4165	4165	105			165					2×40							
4205	4205	130			205					3×40							
4245	4245	155	35 ^{±0.1}	80 ^{±0.1}	245	24	40	M5	10	42.5	4×40	55	—	6.5	—	M3	6
4285	4285	185			285					5×40							
4325	4325	210			325					6×40							
4365	4365	235			365					7×40							
4405	4405	265			405					8×40							

bed-surface mounting hole dimensions														accuracy ※(deviation)		basic load rating		allowable load		allowable static moment			mass		size	
P ₂ mm	d×D×h mm	c ₁ mm	c ₂ mm	f ₁ mm	f ₂ mm	f ₃ mm	f ₄ mm	f ₅ mm	f ₆ mm	f ₇ mm	T μm	S μm	C N	Co N	F N	M _P N·m	M _Y N·m	M _R N·m	SVT g	SVTS g						
40	4.5×8×4.5	9	15	10	35	—	—	—	—	—	2	5	3,490	3,890	1,290	19.4	22.2	54.5	640	300	3055					
					60	—	—	—	—	—	2	5	5,230	6,490	2,160	53.0	58.0	90.9	95.5	440	3080					
					85	—	—	—	—	—	3	6	6,030	7,780	2,590	103	95.7	109	1,250	580	3105					
					110	—	—	—	—	—	3	6	7,560	10,300	3,450	170	160	145	1,570	715	3130					
					135	85	—	—	—	—	3	6	9,000	12,900	4,320	210	220	181	1,850	850	3155					
					160	110	—	—	—	—	3	7	10,300	15,500	5,180	302	314	218	2,150	990	3180					
					185	135	85	—	—	—	3	7	11,000	16,800	5,610	355	367	236	2,450	1,130	3205					
					210	160	110	—	—	—	3	7	11,700	18,100	6,040	472	455	254	2,740	1,270	3230					
					235	185	135	—	—	—	3	7	12,900	20,700	6,910	537	552	290	3,040	1,410	3255					
					260	210	160	110	—	—	3	7	13,600	22,000	7,340	606	622	309	3,360	1,540	3280					
					285	235	185	135	—	—	3	7	14,200	23,300	7,770	757	735	372	3,660	1,680	3305					
					55	5.5×10×5.4	10.5	18	10	65	—	—	—	—	—	2	5	7,110	7,920	2,640	96.0	84.9	159	1,700	780	4085
										105	—	—	—	—	—	3	6	10,600	13,200	4,400	217	199	265	2,500	1,140	4125
										145	—	—	—	—	—	3	7	13,800	18,400	6,160	296	316	371	3,300	1,510	4165
185	105	—	—	—						—	3	7	16,800	23,700	7,920	488	513	477	4,100	1,870	4205					
225	145	—	—	—						—	3	7	19,700	29,000	9,680	729	759	584	4,900	2,240	4245					
265	185	—	—	—						—	3	7	22,400	34,300	11,400	1,010	1,050	690	5,700	2,600	4285					
305	225	145	—	—						—	4	8	25,100	39,600	13,200	1,350	1,390	796	6,500	3,000	4325					
345	265	185	—	—						—	4	8	27,600	44,800	14,900	1,730	1,780	902	7,300	3,300	4365					
385	305	225	—	—						—	4	8	28,900	47,500	15,800	2,160	2,100	955	8,100	3,700	4405					

※For accuracy (T, S), refer to Figure G-18 (page G-25).

1N≒0.102kgf 1N·m≒0.102kgf·m

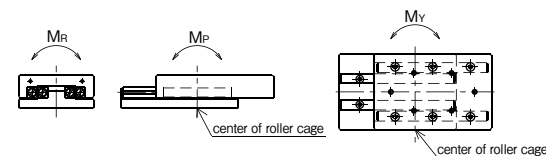

SVT TYPE

-SVT6/SVT9-

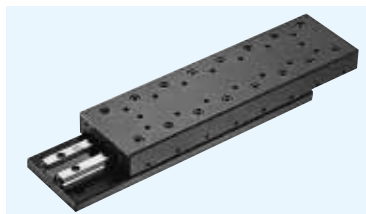

part number structure

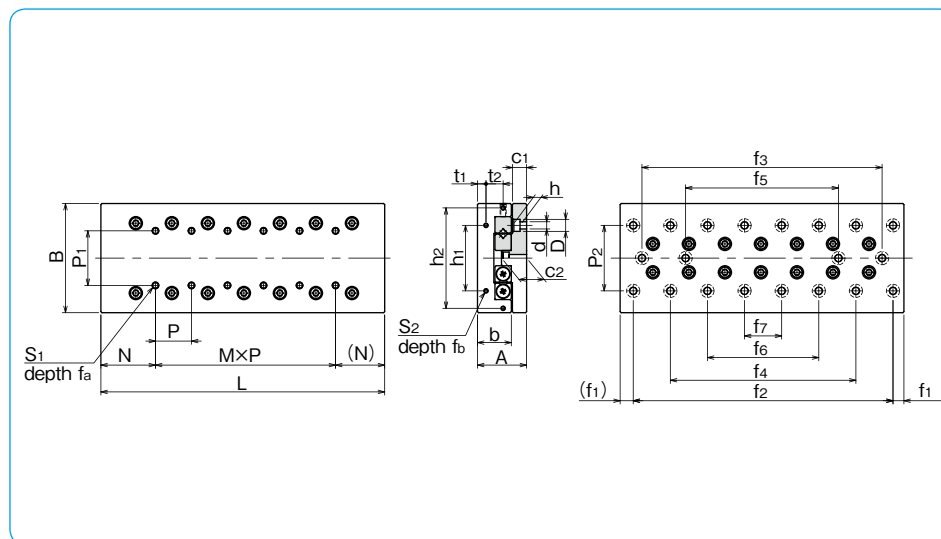
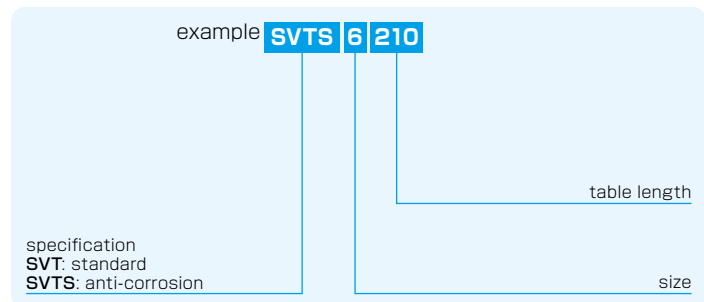

part number		stroke ST mm	major dimensions				table-top mounting hole dimensions					table-end mounting hole dimensions					
standard	anti-corrosion		A mm	B mm	L mm	b mm	P ₁ mm	S ₁ mm	f _a mm	N mm	M×P mm	h ₁ mm	h ₂ mm	t ₁ mm	t ₂ mm	S ₂ mm	f _b mm
SVT 6110	SVTS 6110	60			110					—							
6160	6160	95			160					1×50							
6210	6210	130			210					2×50							
6260	6260	165			260					3×50							
6310	6310	200	45±0.1	100±0.1	310	31	50	M6	12	55	4×50	60	92	8	15	M4	8
6360	6360	235			360					5×50							
6410	6410	265			410					6×50							
6460	6460	300			460					7×50							
6510	6510	335			510					8×50							
SVT 9210	—	130			210					—							
9310	—	180			310					1×100							
9410	—	350			410					2×100							
9510	—	450			510					3×100							
9610	—	550	60±0.1	145±0.1	610	43	85	M8	16	105	4×100	90	135	11	20	M4	8
9710	—	650			710					5×100							
9810	—	750			810					6×100							
9910	—	850			910					7×100							
91010	—	950			1,010					8×100							

bed-surface mounting hole dimensions											accuracy ※(deviation)		basic load rating		allowable load		allowable static moment			mass		size		
P ₂ mm	d×D×h mm	c ₁ mm	c ₂ mm	f ₁ mm	f ₂ mm	f ₃ mm	f ₄ mm	f ₅ mm	f ₆ mm	f ₇ mm	T μm	S μm	C N	Co N	F N	M _P N·m	M _Y N·m	M _R N·m	SVT g	SVTS g				
60	7×11.5×7	13	23	10	90	—	—	—	—	—	3	6	16,500	17,700	5,910	260	230	400	3,280	1,705	6110			
					140	—	—	—	—	—	—	—	—	3	6	24,700	29,600	9,860	588	539	666	4,820	2,480	6160
					190	90	—	—	—	—	—	—	—	3	7	32,200	41,400	13,800	1,040	978	933	6,270	3,255	6210
					240	140	—	—	—	—	—	—	—	3	7	39,200	53,200	17,700	1,630	1,540	1,200	7,740	4,030	6260
					290	190	—	—	—	—	—	—	—	3	7	45,800	65,100	21,600	2,340	2,240	1,460	9,200	4,805	6310
					340	240	140	—	—	—	—	—	—	4	8	52,200	76,900	25,600	2,750	2,850	1,730	10,740	5,580	6360
					390	290	190	—	—	—	—	—	—	4	8	58,400	88,800	29,500	3,660	3,770	2,000	12,190	6,355	6410
					440	340	240	—	—	—	—	—	—	4	8	64,400	100,000	33,500	4,700	4,830	2,260	13,800	7,130	6460
					490	390	290	190	—	—	—	—	—	4	8	70,200	112,000	37,400	5,870	6,010	2,530	15,300	7,905	6510
					90	9×14×9	16	29	55	100	—	—	—	—	—	3	7	51,100	56,500	18,800	1,610	1,440	2,030	12,520
200	—	—	—	—						—	—	—	3	7	79,300	98,900	32,900	3,150	3,360	3,560	17,950	—	9310	
300	100	—	—	—						—	—	—	—	4	8	79,300	98,900	32,900	4,110	3,840	3,560	23,950	—	9410
400	200	—	—	—						—	—	—	—	4	8	96,600	127,000	42,300	6,420	6,080	4,580	30,090	—	9510
500	300	100	—	—						—	—	—	—	4	9	112,000	155,000	51,700	7,760	8,090	5,600	35,990	—	9610
600	400	200	—	—						—	—	—	—	4	9	128,000	183,000	61,100	10,800	11,200	6,620	41,890	—	9710
700	500	300	100	—						—	—	—	—	5	10	136,000	197,000	65,800	14,400	13,900	7,130	47,790	—	9810
800	600	400	200	—						—	—	—	—	5	10	151,000	226,000	75,200	18,500	17,900	8,140	53,690	—	9910
900	700	500	300	100						—	—	—	—	5	10	165,000	254,000	84,600	23,100	22,400	9,160	59,590	—	91010

※For accuracy (T, S), refer to Figure G-18 (page G-25).

1N ≒ 0.102kgf 1N · m ≒ 0.102kgf · m

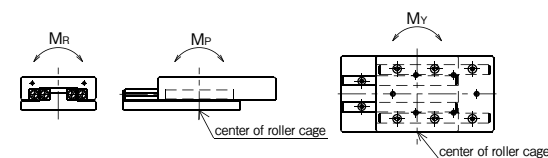

SYT TYPE

-SYT1/SYT2-

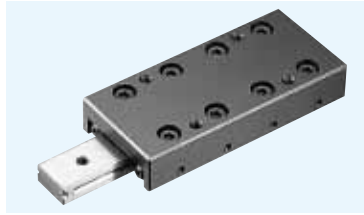

part number structure

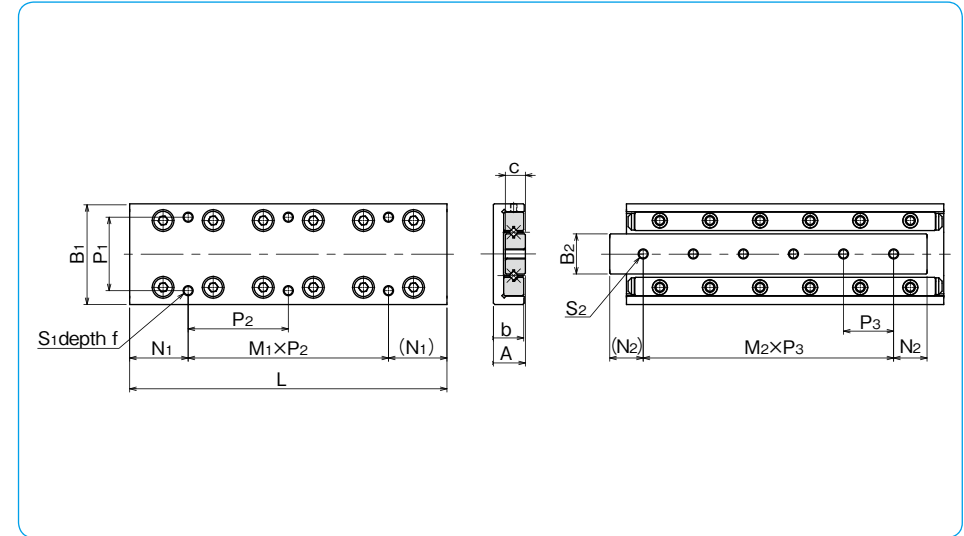
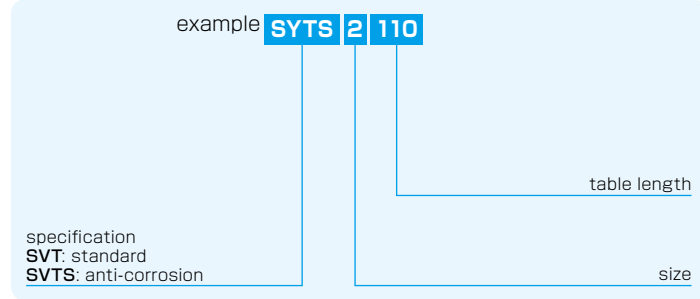

part number		stroke ST mm	major dimensions						table-top mounting hole dimensions		
standard	anti-corrosion		A mm	B ₁ mm	L mm	b mm	B ₂ mm	c mm	P ₁ mm	S ₁	f mm
SYT 1025	SYTS 1025	12	8±0.1	20±0.1	25	7.5	6.6	4	14	M2.6	3
1035	1035	18			35						
1045	1045	25			45						
1055	1055	32			55						
1065	1065	40			65						
1075	1075	45			75						
1085	1085	50			85						
SYT 2035	SYTS 2035	18	12±0.1	30±0.1	35	11.5	12	6	22	M3	5
2050	2050	30			50						
2065	2065	40			65						
2080	2080	50			80						
2095	2095	60			95						
2110	2110	70			110						
2125	2125	80			125						

N ₁ mm	M ₁ ×P ₂ mm	bed-surface mounting hole dimensions		accuracy ※(deviation)		basic load rating		allowable load F N	allowable static moment			mass g	size	
		S ₂	N ₂ mm	M ₂ ×P ₃ mm	T μm	S μm	dynamic C N		static Co N	M _P N·m	M _Y N·m			M _R N·m
3.5	1×18	M2.6	5	2×7.5	2	4	464	476	158	1.79	1.47	1.79	22	1025
3.5	1×28		7.5	2×10	2	4	805	952	316	3.08	3.50	3.58	33	1035
12.5	1×20		7.5	3×10	2	5	959	1,190	396	6.98	6.40	4.48	42	1045
12.5	1×30		7.5	4×10	2	5	1,100	1,420	475	9.53	8.81	5.37	52	1055
12.5	2×20		7.5	5×10	2	5	1,240	1,660	554	12.4	11.6	6.27	63	1065
22.5	1×30		7.5	6×10	2	5	1,510	2,140	712	19.3	18.3	8.06	72	1075
12.5	2×30		7.5	7×10	2	5	1,650	2,380	792	23.4	22.3	8.96	83	1085
3.5	1×28	M3	7.5	1×20	2	4	1,090	1,170	390	7.04	5.78	7.63	79	2035
3.5	1×43		10	2×15	2	4	1,510	1,750	585	12.1	10.7	11.4	113	2050
17.5	1×30		10	3×15	2	5	1,900	2,340	780	19.1	17.1	15.2	150	2065
17.5	1×45		10	4×15	2	5	2,620	3,510	1,170	27.4	29.6	22.8	185	2080
17.5	2×30		10	5×15	2	5	2,950	4,100	1,360	37.4	39.9	26.7	215	2095
32.5	1×45		10	6×15	2	5	3,280	4,680	1,560	61.7	58.1	30.5	255	2110
17.5	2×45		10	7×15	2	5	3,590	5,270	1,750	76.1	72.1	34.3	295	2125

※For accuracy (T, S), refer to Figure G-18 (page G-25).

1N ≒ 0.102kgf 1N · m ≒ 0.102kgf · m

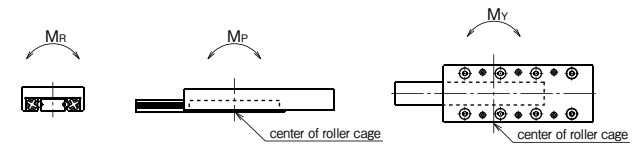

SYT TYPE

-SYT3-

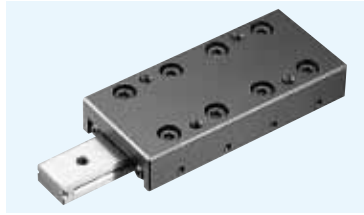

part number structure

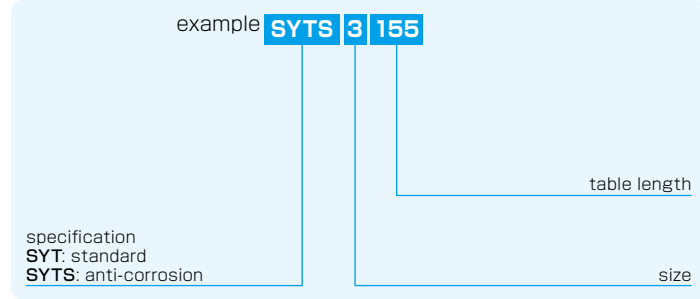

part number		stroke ST mm	major dimensions						table-top mounting hole dimensions		
standard	anti-corrosion		A mm	B ₁ mm	L mm	b mm	B ₂ mm	c mm	P ₁ mm	S ₁	f mm
SYT 3055	SYTS 3055	30	16±0.1	40±0.1	55	15.5	16	8	30	M4	7
3080	3080	45			80						
3105	3105	60			105						
3130	3130	75			130						
3155	3155	90			155						
3180	3180	105			180						
3205	3205	130			205						

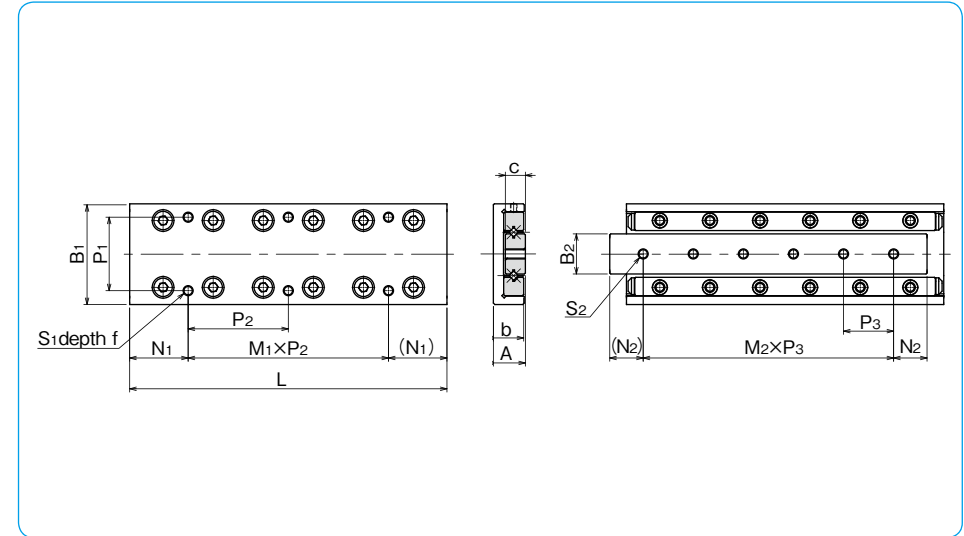

N ₁ mm		M ₁ ×P ₂ mm		bed-surface mounting hole dimensions		accuracy ※(deviation)		basic load rating		allowable load	allowable static moment			mass	size
N ₁	M ₁ ×P ₂	S ₂	N ₂	M ₂ ×P ₃	T μm	S μm	dynamic C N	static Co N	F N	M _P N·m	M _Y N·m	M _R N·m	g		
7.5	1×40	M4	10	1×35	2	5	3,490	3,890	1,290	19.4	22.2	33.8	225	3055	
7.5	1×65		15	2×25	2	5	5,230	6,490	2,160	53.0	58.0	56.4	340	3080	
27.5	1×50		15	3×25	3	5	6,030	7,790	2,590	103	95.7	67.7	440	3105	
27.5	1×75		15	4×25	3	5	7,560	10,300	3,450	170	160	90.3	560	3130	
27.5	2×50		15	5×25	3	5	9,000	12,900	4,320	210	220	112	655	3155	
52.5	1×75		15	6×25	3	5	10,300	15,500	5,180	302	314	135	770	3180	
27.5	2×75		15	7×25	3	5	11,000	16,800	5,610	355	367	146	880	3205	

※For accuracy (T, S), refer to Figure G-18 (page G-25).

1N≒0.102kgf 1N·m≒0.102kgf·m

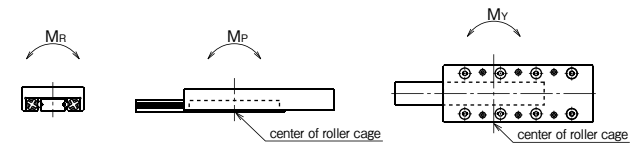

SYT-D TYPE

-SYT1/SYT2-

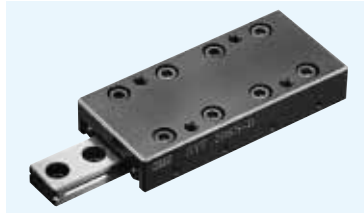

part number structure

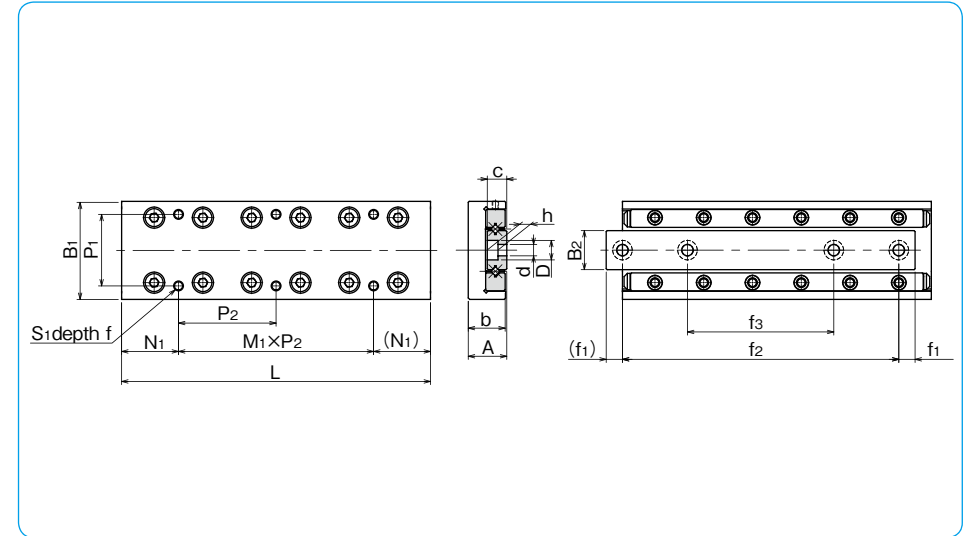
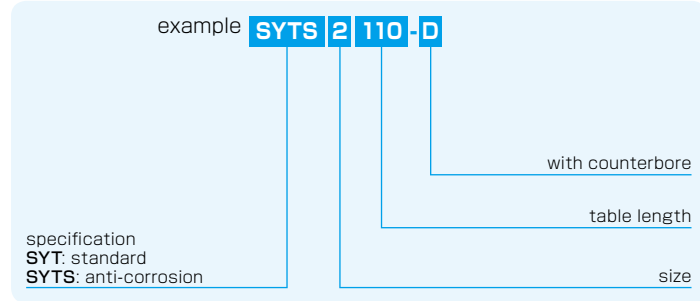

part number		stroke ST mm	major dimensions						table-top mounting hole dimensions			
standard	anti-corrosion		A mm	B ₁ mm	L mm	b mm	B ₂ mm	c mm	P ₁ mm	S ₁ mm	f mm	N ₁ mm
SYT1025-D	SYTS1025-D	12	8±0.1	20±0.1	25	7.5	6.6	4	14	M2.6	3	3.5
1035-D	1035-D	18			35							3.5
1045-D	1045-D	25			45							12.5
1055-D	1055-D	32			55							12.5
1065-D	1065-D	40			65							12.5
1075-D	1075-D	45			75							22.5
1085-D	1085-D	50			85							12.5
SYT2035-D	SYTS2035-D	18			12±0.1							30±0.1
2050-D	2050-D	30	50	3.5								
2065-D	2065-D	40	65	17.5								
2080-D	2080-D	45	80	17.5								
2095-D	2095-D	60	95	17.5								
2110-D	2110-D	70	110	32.5								
2125-D	2125-D	80	125	17.5								

M ₁ ×P ₂ mm	bed-surface mounting hole dimensions			accuracy ※(deviation)		basic load rating		allowable load F N	allowable static moment			mass g	size		
	d×D×h mm	f ₁ mm	f ₂ mm	f ₃ mm	T μm	S μm	dynamic C N		static Co N	M _P N·m	M _Y N·m			M _R N·m	
1×18	2.5×4.1×2.2	3.5	18	—	2	4	464	476	158	1.79	1.47	1.79	22	1025	
1×28		5	25	—	2	4	805	952	316	3.08	3.50	3.58	33	1035	
1×20		3.5	38	25	2	5	959	1,190	396	6.98	6.40	4.48	42	1045	
1×30		3.5	48	29	2	5	1,100	1,420	475	9.53	8.81	5.37	52	1055	
2×20		5	55	31	2	5	1,240	1,660	554	12.4	11.6	6.27	63	1065	
1×30		5	65	35	2	5	1,510	2,140	712	19.3	18.3	8.06	72	1075	
2×30		5	75	40	2	5	1,650	2,380	792	23.4	22.3	8.96	83	1085	
1×28		3.5×6×3.3	5	25	—	2	4	1,090	1,170	390	7.04	5.78	7.63	79	2035
1×43			7.5	35	—	2	4	1,510	1,750	585	12.1	10.7	11.4	113	2050
1×30			5	55	33	2	5	1,900	2,340	780	19.1	17.1	15.2	150	2065
1×45	5		70	40	2	5	2,620	3,510	1,170	27.4	29.6	22.8	185	2080	
2×30	5		85	45	2	5	2,950	4,100	1,360	37.4	39.9	26.7	215	2095	
1×45	7.5		95	50	2	5	3,280	4,680	1,560	61.7	58.1	30.5	255	2110	
2×45	7.5		110	55	2	5	3,590	5,270	1,750	76.1	72.1	34.3	295	2125	

※For accuracy (T, S), refer to Figure G-18 (page G-25).

1N≒0.102kgf 1N·m≒0.102kgf·m

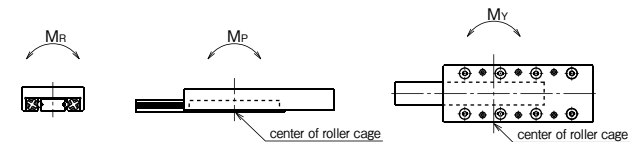

SYT-D TYPE

-SYT3-

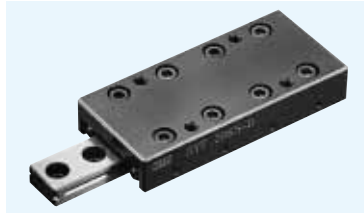

part number structure

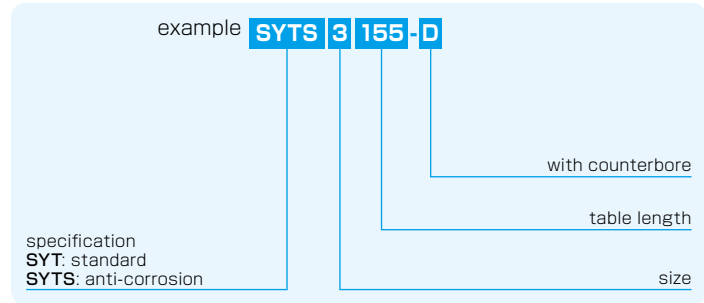

part number		stroke ST mm	major dimensions						table-top mounting hole dimensions			
standard	anti-corrosion		A mm	B ₁ mm	L mm	b mm	B ₂ mm	c mm	P ₁ mm	S ₁	f mm	N ₁ mm
SYT3055-D	SYTS3055-D	30	16±0.1	40±0.1	55	15.5	16	8	30	M4	7	7.5
3080-D	3080-D	45			80							7.5
3105-D	3105-D	60			105							27.5
3130-D	3130-D	75			130							27.5
3155-D	3155-D	90			155							27.5
3180-D	3180-D	105			180							52.5
3205-D	3205-D	130			205							27.5

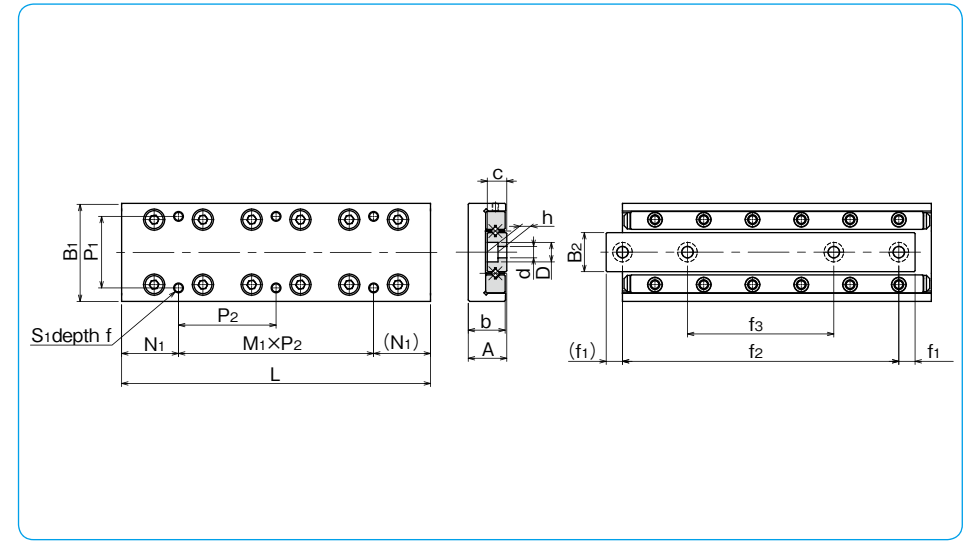

M ₁ × P ₂ mm	bed-surface mounting hole dimensions			accuracy ※(deviation)		basic load rating		allowable load F N	allowable static moment			mass g	size	
	d × D × h mm	f ₁ mm	f ₂ mm	f ₃ mm	T μm	S μm	dynamic C N		static Co N	M _P N · m	M _Y N · m			M _R N · m
1 × 40	4.5 × 7.5 × 4.3	7.5	40	—	2	5	3,490	3,890	1,290	19.4	22.2	33.8	225	3055
1 × 65		6	68	43	2	5	5,230	6,490	2,160	53.0	58.0	56.4	340	3080
1 × 50		7.5	90	55	3	5	6,030	7,780	2,590	103	95.7	67.7	440	3105
1 × 75		7.5	115	65	3	5	7,560	10,300	3,450	170	160	90.3	560	3130
2 × 50		7.5	140	95	3	5	9,000	12,900	4,320	210	220	112	655	3155
1 × 75		7.5	165	85	3	5	10,300	15,500	5,180	302	314	135	770	3180
2 × 75		7.5	190	90	3	5	11,000	16,800	5,610	355	367	146	880	3205

※For accuracy (T, S), refer to Figure G-18 (page G-25).

1N ≒ 0.102kgf 1N · m ≒ 0.102kgf · m

