

# BALL SPLINE

The NB ball spline is a linear motion mechanism utilizing the rotational motion of ball elements that can sustain loads and at the same time can transfer torque. It can be used in a wide variety of applications including robotics and transport type equipment.

## STRUCTURE AND ADVANTAGES

The NB ball spline consists of a spline shaft with raceway grooves and a spline nut. The spline nut consists of an outer cylinder (main body), retainer, side rings, and ball elements that is designed and manufactured to achieve a reliably smooth motion.

### High Load Capacity and Long Travel Life

The raceway grooves are machined to a radius close to that of the ball elements. The large ball contact area results in high load capacity and long travel life.

### Wide Variety of Configurations

Spline shaft sizes with diameters from 4mm to 100mm are available. Several types of Spline nut are available: cylindrical types (SSP/SSPM), and flange types (SSPF/SSPT). Material option of Stainless steel (SUS440C or equivalent) is also available. They can be specified to suit various applications.

### High Accuracy Torque Transmission

Due to the effective contact angle between the raceway grooves and the balls, the NB ball spline can transfer large torque. By adjusting preload it is possible to give a higher rigidity and a higher positioning accuracy.

### Ease of Additional Custom Machining

Since a round shaft with raceway grooves is used, NB ball spline shafts can be machined easily to customized specifications.

### High-Speed Motion and High-Speed Rotation

The outer cylinder is compact and well balanced, resulting in good performance at high speed.

Figure B-1 Basic Structure of NB Ball Spline

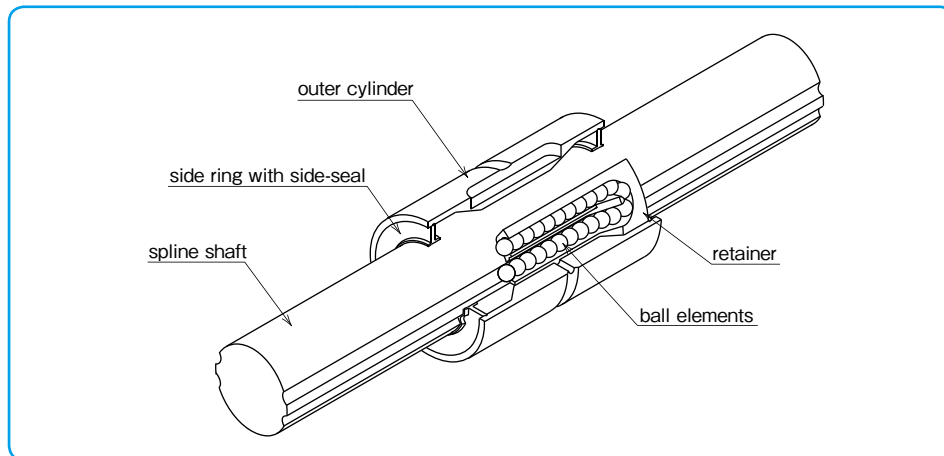

## TYPES

### TYPES OF SPLINE NUT

A wide variety of spline nut designs are available and all spline nuts come with side-seals as a standard feature.

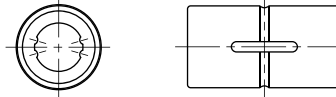
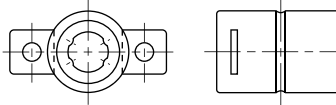
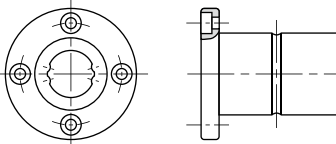
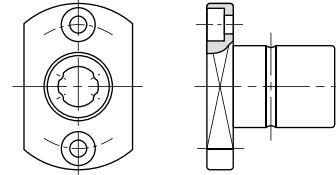

Table B-1 Types of Spline Nut

type of nut		shape and advantage	page
cylindrical type	SSP SSPS	 <ul style="list-style-type: none"> <li>cylindrical spline nut with key groove</li> <li>with special key</li> <li>nominal diameter: SSP4-100 : SSPS4-25</li> </ul>	P.B-18
	SSPM	 <ul style="list-style-type: none"> <li>cylindrical spline nut without key groove</li> <li>with two lock plates for fixing</li> <li>nominal diameter: 6-10</li> </ul>	P.B-20
flange type	SSPF SSPFS	 <ul style="list-style-type: none"> <li>spline nut with flange</li> <li>nominal diameter: SSPF6-60 : SSPFS6-25</li> </ul>	P.B-22
	SSPT	 <ul style="list-style-type: none"> <li>spline nut with a two side cut flange</li> <li>nominal diameter: 6-10</li> </ul>	P.B-24

TYPES OF SPLINE SHAFT

Depending on the application requirements, either a ground spline shaft or a non-ground (commercial grade) spline shaft is available.

Table B-2

type of spline shaft	shape and advantage
ground spline shaft	 <ul style="list-style-type: none"> <li>• precision ground and precision machined surface finish</li> <li>• high precision</li> <li>• possible to machine ends of spline shaft and surface treatment</li> <li>• nominal diameter: 4-100</li> </ul>
standard spline shaft	 <ul style="list-style-type: none"> <li>• standard dimension and shape</li> <li>• accuracy grade: high grade</li> <li>• short lead time</li> <li>• nominal diameter: 4-60 (refer to page B-26)</li> </ul>
commercial shaft (non-ground)	 <ul style="list-style-type: none"> <li>• for general industrial use</li> <li>• cost effective</li> <li>• possible to machine ends of spline shaft and surface treatment</li> <li>• nominal diameter: 20-50</li> <li>• maximum length: 5000mm (refer to page B-27)</li> </ul>

ACCURACY

The NB ball spline is measured for accuracy at the points shown in Figure B-2 and categorized as either high-grade (blank) or precision-grade (P). Contact NB for accuracy information on the commercial type ball spline. Figure B-2 Accuracy Measurement Points

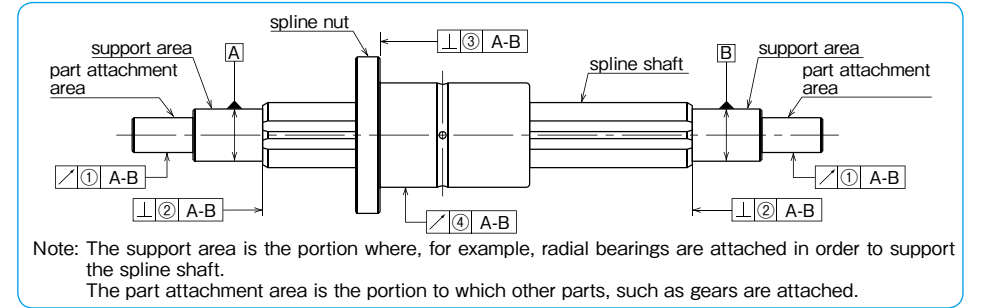

Tolerance of Spline Shaft Groove Torsion (Max.)

The groove torsion is indicated per 100mm, arbitrarily set as the effective length of the spline shaft section.

Table B-3  
Tolerance of Spline Shaft Groove Torsion (Max.)

type of shaft	ground shaft	
	high	precision (P)
accuracy grade		
tolerance	13 μm/100mm	6 μm/100mm

Table B-4 Tolerance Relative to Spline Support Area (Max.)

part number	unit/μm					
	radial runout of part attachment area ①		perpendicularity of the end of the spline shaft section ② (when grinding is requested on the drawing)		perpendicularity of the flange ③	
	high-grade	precision-grade	high-grade	precision-grade	high-grade	precision-grade
SSP 4					—	—
SSP 6	14	8	9	6	11	8
SSP 8						
SSP 10						
SSP 13A	19	12	11	8	13	9
SSP 16A						
SSP 20A						
SSP 25A	22	13	13	9	16	11
SSP 30A						
SSP 40A						
SSP 50A	25	15	16	11	19	13
SSP 60A						
SSP 80						
SSP 80L	29	17	19	13	—	—
SSP 100						
SSP 100L						
SSP 20	19	12	11	8	13	9
SSP 25						
SSP 30						
SSP 40	25	15	16	11	19	13
SSP 50						
SSP 60						

Table B-5 ④ Radial Runout of Outer Surface of Spline Nut Relative to Spline Shaft Support Area (Max.) unit/μm

total length of spline shaft (mm)	greater than	or less	SSP4		SSP6		SSP8		SSP10		part number															
			high-grade	precision-grade	high-grade	precision-grade	high-grade	precision-grade	high-grade	precision-grade	SSP13A SSP16A	SSP20A-20 SSP25A-25 SSP30A-30	SSP40A-40 SSP50A-50	SSP60A-60 SSP80 SSP80L	SSP100 SSP100L											
—	200	46	26	46	26	46	26	36	20	34	18	32	18	32	16	30	16	30	16							
200	315	89	—	89	57	89	57	54	32	45	25	39	21	36	19	34	17	32	17							
315	400	—	—	126	—	126	82	68	41	53	31	44	25	39	21	36	19	34	17							
400	500	—	—	—	—	163	—	82	51	62	38	50	29	43	24	38	21	35	19							
500	630	—	—	—	—	—	—	102	65	75	46	57	34	47	27	41	23	37	20							
630	800	—	—	—	—	—	—	—	—	92	58	68	42	54	32	45	26	40	22							
800	1,000	—	—	—	—	—	—	—	—	115	75	83	52	63	38	51	30	43	24							
1,000	1,250	—	—	—	—	—	—	—	—	153	97	102	65	76	47	59	35	48	28							
1,250	1,600	—	—	—	—	—	—	—	—	195*	127*	130	85	93	59	70	43	55	33							
1,600	2,000	—	—	—	—	—	—	—	—	—	—	171	116	118	77	86	54	65	40							

★ SSP13A, 16A maximum length: 1500mm  
 ★★ Please contact NB for shaft lengths exceeding 2000mm.

PRELOAD AND CLEARANCE IN ROTATIONAL DIRECTION

Both the clearance and preload are expressed in terms of clearance in the rotational direction. The preload is categorized into three different levels: standard, light (T1), and medium (T2). A preload cannot be specified with the commercial grade spline shaft.

Table B-6 Preload and Clearance in Rotational Direction unit/μm

part number	standard	light (T1)	medium (T2)
SSP 4	-2~+1	- 6~-2	-
SSP 6			
SSP 8			
SSP 10	-3~+1	- 8~-3	-13~- 8
SSP 13A			
SSP 16A			
SSP 20A	-4~+2	-12~-4	-20~-12
SSP 25A			
SSP 30A			
SSP 40A	-6~+3	-18~-6	-30~-18
SSP 50A			
SSP 60A			
SSP 80			
SSP 80L	-8~+4	-24~-8	-40~-24
SSP100			
SSP100L			
SSP 20	-4~+2	-12~-4	-20~-12
SSP 25			
SSP 30			
SSP 40	-6~+3	-18~-6	-30~-18
SSP 50			
SSP 60			

Table B-7 Operating Condition and Preload

preload	preload symbol	operating conditions
standard	blank	minute vibration is applied. a precise motion is required. a torque in a given direction is applied.
light	T1	slight vibration is applied. slight torsional load is applied. cyclic torque is applied.
medium	T2	shock/vibration is applied. over-hang load is applied. torsional load is applied.

STRENGTH OF SPLINE SHAFT

The ball spline has larger load ratings compared to ball bush. Also, the ball spline can sustain radial load, moment (bending moment) and torque (twisting moment) at the same time. Thus, it is necessary to consider the strength of ball spline shaft.

Using the following equations, select the size of ball

$$\sigma \geq \frac{M}{Z} \dots\dots\dots (1)$$

σ: permissible bending stress of spline shaft (98N/mm<sup>2</sup>)  
 M: bending moment onto spline shaft (N·mm)  
 Z: modulus of section (mm<sup>3</sup>)  
 (refer to Table B-8 on page B-8)

Twisting Moment Only

$$\tau_a \geq \frac{T}{Z_p} \dots\dots\dots (2)$$

T<sub>a</sub>: permissible twisting stress of spline shaft (49N/mm<sup>2</sup>)  
 T: twisting moment onto spline shaft (N·mm)  
 Z<sub>p</sub>: polar modulus of section (mm<sup>3</sup>)  
 (refer to Table B-8 on page B-8)

Bending Moment and Twisting Moment Combined

Calculate equivalent bending moment (Me) by using equation (3). Then, substitute Me into equation (1) for shaft size selection.

$$M_e = \frac{1}{2} \{ (M + \sqrt{M^2 + T^2}) \} \dots\dots\dots (3)$$

Me: equivalent bending moment (N·mm)  
 M: bending moment onto spline shaft  
 T: twisting moment onto spline shaft

Rigidity of Spline Shaft

The rigidity of spline shaft is expressed in the torsional angle (θ) caused by twisting moment. For high accuracy smooth motion, it is necessary to keep the torsional angle within 0.25° per 1,000mm.

$$\theta = \frac{T \cdot L}{G \cdot I_p} \cdot \frac{360}{2\pi} \dots\dots\dots (4)$$

$$\text{Rigidity} = 0.25^\circ \geq \frac{1,000}{L} \theta \dots\dots\dots (5)$$

θ: torsional angle (°)  
 T: twisting moment onto spline shaft (N·mm)  
 L: spline shaft length (mm)  
 G: shearing modulus (SUJ2) 7.9×10<sup>4</sup> (N/mm<sup>2</sup>)  
 (SUS) 7.69×10<sup>4</sup> (N/mm<sup>2</sup>)  
 I<sub>p</sub>: polar moment of inertia of area (mm<sup>4</sup>)  
 (refer to Table B-8 on page B-8)

Figure B-3 Bending Moment

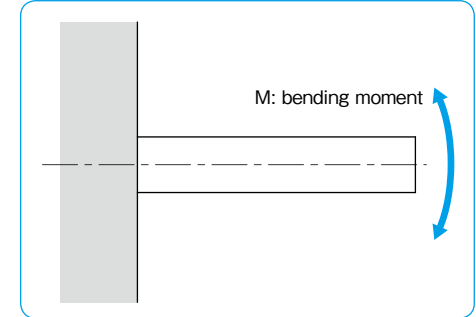

Figure B-4 Twisting Moment

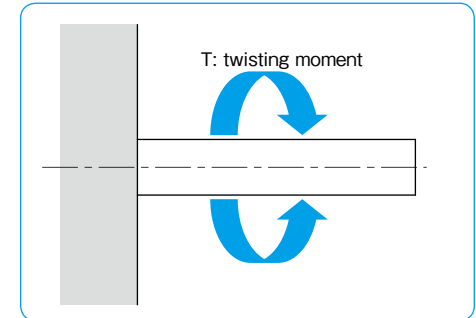

Figure B-5 Deformation of Spline Shaft by Twisting Moment

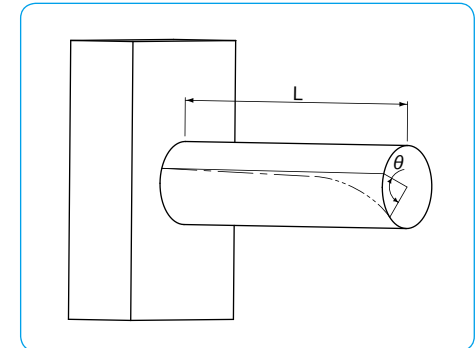

Table B-8 Cross-sectional Characteristics of Spline Shaft

part number	I moment of inertia of area mm <sup>4</sup>	Z modulus of section mm <sup>3</sup>	I <sub>p</sub> polar moment of inertia of area mm <sup>4</sup>	Z <sub>p</sub> polar modulus of section mm <sup>3</sup>	C=1/48EI	
					SUJ2	SUS440C
1/N·mm <sup>2</sup>						
SSP 4	1.18×10	5.90	2.41×10	1.20×10	8.57×10 <sup>-9</sup>	8.83×10 <sup>-9</sup>
SSP 6	5.91×10	1.97×10	1.21×10 <sup>2</sup>	4.04×10	1.71×10 <sup>-9</sup>	1.76×10 <sup>-9</sup>
SSP 8	1.90×10 <sup>2</sup>	4.76×10	3.88×10 <sup>2</sup>	9.69×10	5.32×10 <sup>-10</sup>	5.47×10 <sup>-10</sup>
SSP 10	4.61×10 <sup>2</sup>	9.22×10	9.42×10 <sup>2</sup>	1.88×10 <sup>2</sup>	2.19×10 <sup>-10</sup>	2.26×10 <sup>-10</sup>
SSP 13A	1.32×10 <sup>3</sup>	2.03×10 <sup>2</sup>	2.70×10 <sup>3</sup>	4.16×10 <sup>2</sup>	7.66×10 <sup>-11</sup>	7.89×10 <sup>-11</sup>
SSP 16A	2.98×10 <sup>3</sup>	3.73×10 <sup>2</sup>	6.15×10 <sup>3</sup>	7.68×10 <sup>2</sup>	3.39×10 <sup>-11</sup>	3.49×10 <sup>-11</sup>
SSP 20A	7.35×10 <sup>3</sup>	7.35×10 <sup>2</sup>	1.51×10 <sup>4</sup>	1.51×10 <sup>3</sup>	1.38×10 <sup>-11</sup>	1.42×10 <sup>-11</sup>
SSP 25A	1.79×10 <sup>4</sup>	1.43×10 <sup>3</sup>	3.68×10 <sup>4</sup>	2.94×10 <sup>3</sup>	5.65×10 <sup>-12</sup>	5.82×10 <sup>-12</sup>
SSP 30A	3.63×10 <sup>4</sup>	2.42×10 <sup>3</sup>	7.57×10 <sup>4</sup>	5.05×10 <sup>3</sup>	2.79×10 <sup>-12</sup>	—
SSP 40A	1.15×10 <sup>5</sup>	5.73×10 <sup>3</sup>	2.39×10 <sup>5</sup>	1.20×10 <sup>4</sup>	8.83×10 <sup>-13</sup>	—
SSP 50A	2.81×10 <sup>5</sup>	1.12×10 <sup>4</sup>	5.86×10 <sup>5</sup>	2.34×10 <sup>4</sup>	3.60×10 <sup>-13</sup>	—
SSP 60A	5.91×10 <sup>5</sup>	1.97×10 <sup>4</sup>	1.22×10 <sup>6</sup>	4.08×10 <sup>4</sup>	1.71×10 <sup>-13</sup>	—
SSP 80	1.93×10 <sup>6</sup>	4.83×10 <sup>4</sup>	3.92×10 <sup>6</sup>	9.81×10 <sup>4</sup>	5.24×10 <sup>-14</sup>	—
SSP 80L						
SSP100	4.69×10 <sup>6</sup>	9.38×10 <sup>4</sup>	9.55×10 <sup>6</sup>	1.91×10 <sup>5</sup>	2.16×10 <sup>-14</sup>	—
SSP100L						
SSP 20	5.03×10 <sup>3</sup>	5.53×10 <sup>2</sup>	1.04×10 <sup>4</sup>	1.14×10 <sup>3</sup>	2.01×10 <sup>-11</sup>	2.07×10 <sup>-11</sup>
SSP 25	1.27×10 <sup>4</sup>	1.10×10 <sup>3</sup>	2.63×10 <sup>4</sup>	2.29×10 <sup>3</sup>	7.97×10 <sup>-12</sup>	8.21×10 <sup>-12</sup>
SSP 30	2.74×10 <sup>4</sup>	1.96×10 <sup>3</sup>	5.73×10 <sup>4</sup>	4.10×10 <sup>3</sup>	3.69×10 <sup>-12</sup>	—
SSP 40	8.71×10 <sup>4</sup>	4.66×10 <sup>3</sup>	1.82×10 <sup>5</sup>	9.75×10 <sup>3</sup>	1.16×10 <sup>-12</sup>	—
SSP 50	2.16×10 <sup>5</sup>	9.19×10 <sup>3</sup>	4.53×10 <sup>5</sup>	1.93×10 <sup>4</sup>	4.69×10 <sup>-13</sup>	—
SSP 60	4.50×10 <sup>5</sup>	1.59×10 <sup>4</sup>	9.46×10 <sup>5</sup>	3.35×10 <sup>4</sup>	2.25×10 <sup>-13</sup>	—

CALCULATION OF DEFLECTION AND DEFLECTION ANGLE OF SPLINE SHAFT

The following formulas are used to obtain the deflection and its angle of the ball spline shaft. Typical conditions are listed in Table B-9.

Table B-9 Formulas for Calculating Deflection and Deflection Angle

support method	specification	formula for deflection	formula for deflection angle
1 support   support		$\delta_{max} = \frac{P\ell^3}{48EI} = P\ell^3C$	$i_1 = 0$ $i_2 = \frac{P\ell^2}{16EI} = 3P\ell^2C$
2 fixed   fixed		$\delta_{max} = \frac{P\ell^3}{192EI} = \frac{1}{4}P\ell^3C$	$i_1 = 0$ $i_2 = 0$
3 support   support		$\delta_{max} = \frac{5p\ell^4}{384EI} = \frac{5}{8}p\ell^4C$	$i_2 = \frac{p\ell^3}{24EI} = 2p\ell^3C$
4 fixed   fixed		$\delta_{max} = \frac{p\ell^4}{384EI} = \frac{1}{8}p\ell^4C$	$i_2 = 0$
5 support   support		$\delta_1 = \frac{Pa^3}{6EI} \left(2 + \frac{3b}{a}\right) = 8Pa^3 \left(2 + \frac{3b}{a}\right)C$ $\delta_{max} = \frac{Pa^3}{24EI} \left(\frac{3\ell^2}{a^2} - 4\right) = 2Pa^3 \left(\frac{3\ell^2}{a^2} - 4\right)C$	$i_1 = \frac{Pab}{2EI} = 24PabC$ $i_2 = \frac{Pa(a+b)}{2EI} = 24Pa(a+b)C$
6 fixed   fixed		$\delta_1 = \frac{Pa^3}{6EI} \left(2 - \frac{3a}{\ell}\right) = 8Pa^3 \left(2 - \frac{3a}{\ell}\right)C$ $\delta_{max} = \frac{Pa^3}{24EI} \left(2 + \frac{3b}{a}\right) = 2Pa^3 \left(2 + \frac{3b}{a}\right)C$	$i_1 = \frac{Pa^2b}{2EI\ell} = \frac{24Pa^2bC}{\ell}$ $i_2 = 0$
7 fixed   free		$\delta_{max} = \frac{P\ell^3}{3EI} = 16P\ell^3C$	$i_1 = \frac{P\ell^2}{2EI} = 24P\ell^2C$ $i_2 = 0$
8 fixed   free		$\delta_{max} = \frac{p\ell^4}{8EI} = 6p\ell^4C$	$i_1 = \frac{p\ell^3}{6EI} = 8p\ell^3C$ $i_2 = 0$
9 support   support		$\delta_{max} = \frac{\sqrt{3}Mo\ell^2}{216EI} = \frac{2\sqrt{3}}{9}Mo\ell^2C$	$i_1 = \frac{Mo\ell}{12EI} = 4Mo\ell C$ $i_2 = \frac{Mo\ell}{24EI} = 2Mo\ell C$
10 fixed   fixed		$\delta_{max} = \frac{Mo\ell^2}{216EI} = \frac{2}{9}Mo\ell^2C$	$i_1 = \frac{Mo\ell}{16EI} = 3Mo\ell C$ $i_2 = 0$

$\delta_1$ : deflection at the concentrated load point (mm)  $\delta_{max}$ : maximum deflection (mm)  $i_1$ : deflection angle at the concentrated load point (rad)  $i_2$ : deflection angle at the support point (rad)  $Mo$ : moment (N·mm)  $P$ : concentrated load (N)  $p$ : uniformly distributed load (N/mm)  $a, b$ : concentrated load point distance (mm)  $\ell$ : span (mm)  $I$ : moment of inertia of area (mm<sup>4</sup>) (refer to Table B-8 on page B-8)  $E$ : modulus of longitudinal elasticity (SUJ2)  $2.06 \times 10^5$  (N/mm<sup>2</sup>) (SUS)  $2.0 \times 10^5$  (N/mm<sup>2</sup>)  $C$ :  $1/48EI$  (1/N·mm<sup>2</sup>)

## ALLOWABLE ROTATIONAL SPEED OF SPLINE SHAFT

When the rotational speed is increased and approaches the spline shaft resonant frequency, the spline shaft is disabled from further operation. This speed is called the critical speed and can be obtained by the following equations. In order to leave a sufficient safety margin, the allowable operating speed should be set at about 80% of the calculated value.

Using the following equations, select the size of ball spline shaft. First, calculate  $\lambda$  and A by equation (8) and (9) then, substitute the values into equation (7).

$$N_c = 60 \cdot \frac{\lambda^2}{2\pi \cdot L^2} \cdot \sqrt{\frac{E \cdot I_d \times 10^3}{\gamma \cdot A}} \dots \dots \dots (7)$$

$N_c$ : critical speed (rpm)  
 $L$ : support distance (mm)  
 $E$ : modulus of longitudinal elasticity (SUJ2)  $2.06 \times 10^5$  (N/mm<sup>2</sup>)  
 (SUS)  $2.0 \times 10^5$  (N/mm<sup>2</sup>)  
 $\gamma$ : density (SUJ2)  $7.85 \times 10^{-6}$  (kg/mm<sup>3</sup>)  
 (SUS)  $7.75 \times 10^{-6}$  (kg/mm<sup>3</sup>)

$I_d$ : Minimum Moment of Inertia of Area (mm<sup>4</sup>)

$$I_d = \frac{\pi \cdot d^4}{64} \dots \dots \dots (8)$$

$d$ : maximum machined-down diameter with no spline grooves left (refer to Table B-10)

A: Minimum Cross-sectional Area of the Spline Shaft (mm<sup>2</sup>)

$$A = \frac{\pi \cdot d^2}{4} \dots \dots \dots (9)$$

$d$ : maximum machined-down diameter with no spline grooves left (refer to Table B-10)

$\lambda$ : coefficient by mounting method (refer to Figure B-6)

- fixed-free  $\lambda = 1.875$
- supported-supported  $\lambda = 3.142$
- fixed-supported  $\lambda = 3.927$
- fixed-fixed  $\lambda = 4.730$

Table B-10 Spline Shaft Profile

part number	d: maximum diameter with no spline grooves left mm	part number	d: maximum diameter with no spline grooves left mm
SSP 4	3.5	SSP 80	73.9
SSP 6	5.3	SSP 80L	
SSP 8	7.2	SSP100	92
SSP 10	9	SSP100L	
SSP 13A	11.7		
SSP 16A	14.2	SSP 20	16.4
SSP 20A	17.9	SSP 25	20.6
SSP 25A	22.4	SSP 30	24.8
SSP 30A	26.8	SSP 40	33.1
SSP 40A	35.5	SSP 50	41.4
SSP 50A	44.6	SSP 60	49.7
SSP 60A	54		

The maximum diameter (d) is recommended as the shaft diameter of the support area leaving no spline grooves after end-machining.

Figure B-6 Mounting Method

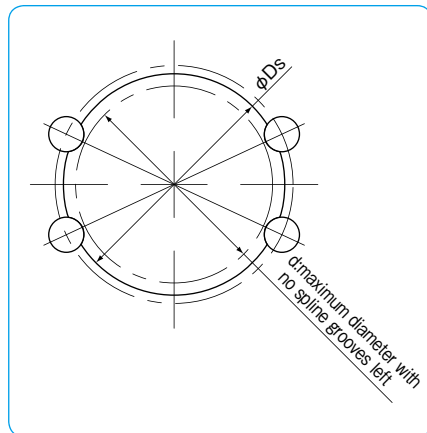
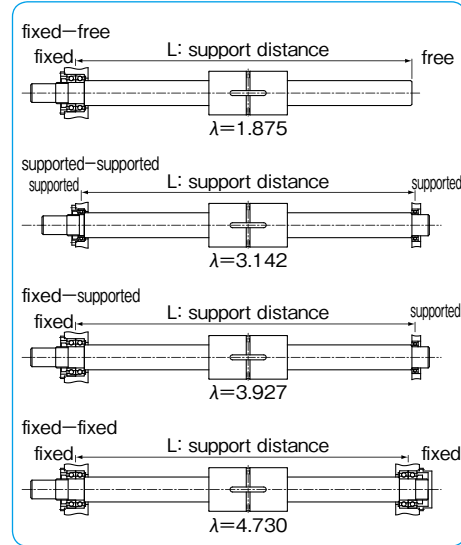

## RATED LIFE

When the ball elements are used as the rolling elements in ball splines, the following equations are used to calculate the life of ball spline.

For radial load

$$L = \left( \frac{f_c}{f_w} \cdot \frac{C}{P} \right)^3 \cdot 50$$

For torque load

$$L = \left( \frac{f_c}{f_w} \cdot \frac{C_T}{T} \right)^3 \cdot 50$$

$L$ : rated life (km)  $f_c$ : contact coefficient  $f_w$ : load coefficient  
 $C$ : basic dynamic load rating (N)  $P$ : applied load (N)  
 $C_T$ : basic dynamic torque rating (N·m)  $T$ : applied torque (N·m)

\* Refer to page Eng-5 for the coefficients  
 \*\* The load rating of the commercial spline is approximately 70% of the standard ball spline.

$$L_h = \frac{L \cdot 10^3}{2 \cdot \ell_s \cdot n_1 \cdot 60}$$

$L_h$ : life time (hr)  $\ell_s$ : stroke length (m)  
 $L$ : rated life (km)  $n_1$ : number of cycles per minute (cpm)

## OPERATING CONDITIONS

The performance of the ball spline is affected by the operating conditions of the application. The operating conditions should therefore be carefully taken into consideration.

### Dust Prevention

Foreign particles or dust in the ball spline nut affects the motion accuracy and shortens the life time. Standard seals will perform well for dust prevention under normal operating conditions, however, in a harsh environment it is necessary to attach bellows or protective covers. (refer to Figure B-8)

### Operating Temperature

The retainer is made of resin, so the operating temperature should never exceed 80°C.

### Excessive Moment

One spline nut can sustain high moment, however, excessive moment makes the spline nut unbalanced and unstable in motion. Please use more than one spline nut for high moment or high accuracy applications.

Figure B-7 Radial Load and Torque Load

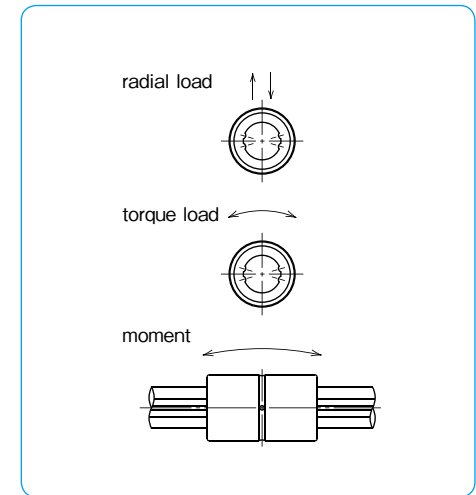
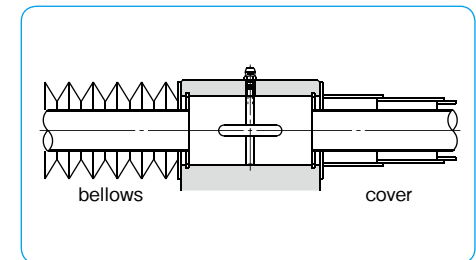

Figure B-8 Example of Dust Prevention



## LUBRICATION

The spline nut is prelubricated with lithium soap based grease prior to shipment for immediate use. Please relubricate with a similar type of grease periodically depending on the operating conditions. Low dust generation grease is available from NB standard grease. (refer to page Eng-39) The NB spline nut has seals as standard. The seals work well to contain the grease inside the nut especially for the ground shaft, since the seal shape approximates the spline shaft profile.

Figure B-9 Example of Lubrication Mechanism

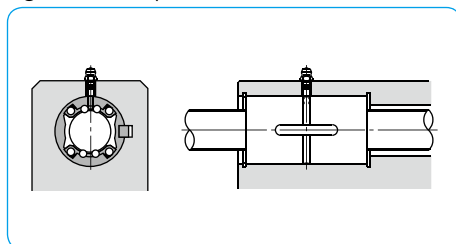

## SPECIAL REQUIREMENTS

Based on customer drawings and requirements NB does shaft-end machining, spline nut machining, surface treatment, etc. Please contact NB for special requirements. Table B-11 shows a list of recommended inner diameters for hollow spline shaft.

Figure B-10 Example of Shaft-end Machining

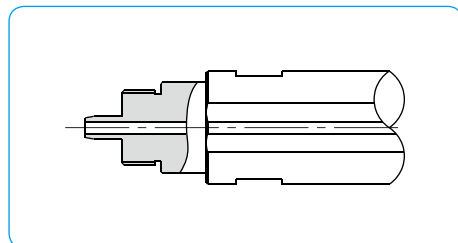
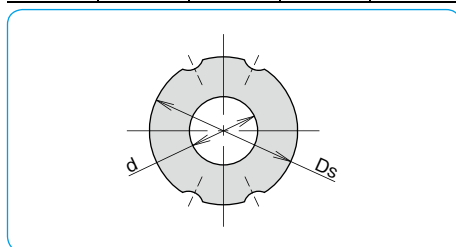

Table B-11 Recommended Inner Diameter for Hollow Spline Shaft

part number	shaft diameter Ds mm	inner diameter d mm	cross-sectional coefficient Z mm <sup>3</sup>	second moment of inertia I mm <sup>4</sup>
SSP 4	4	1.5	5.7	11
SSP 6	6	2	19.4	58
SSP 8	8	3	46.5	186
SSP10	10	4	89.6	448
SSP13A	13	6	193	1,260
SSP16A	16	8	348	2,780
SSP20A	20	10	686	6,860
SSP25A	25	15	1,230	15,400



## PRECAUTIONS ON MOUNTING

NB ball spline must be handled with care as a precision component. Please note the following points.

### A Set of Spline Nut and Spline Shaft

The ball spline accuracy and preload is guaranteed when spline nut and shaft are aligned as shown in Figure B-11. Please make sure to align the NB marks when reinserting the shaft.

When inserting the spline shaft into the spline nut, ensure that the ball elements do not drop out. This is done by aligning the raceway grooves of the shaft with the rows of ball elements and the seal lip of the nut. Then carefully insert the spline shaft through the spline nut. In case that the nut is preloaded, please exercise added care.

### Fit between Spline Nut and Housing

A transition fit is used for the SSP/SSPM-type spline nut and its housing bore to minimize the clearance. If high accuracy is not required, then a clearance fit can be used. For the SSPT/SSPF type spline nut, for a light load and little torque application a hole slightly larger than the outer diameter of the nut can suffice. The mounting surface for the flange influences the perpendicularity and parallelism. Please make sure of the accuracy of the mounting surface.

### Insertion of Spline Nut

When inserting a spline nut into the housing, use a jig like the one shown in Figure B-12. Carefully insert the nut so as not to hit the side ring and seal.

Table B-13 Recommended Jig Dimensions unit/mm

part number	D	d	part number	D	d
SSP 4	9.5	3.5	SSP 20	31.5	16.5
SSP 6	13.5	5	SSP 25	36.5	20.5
SSP 8	15.5	7	SSP 30	44.5	25
SSP 10	20.5	8.5	SSP 40	59.5	33
SSP 13A	23.5	12	SSP 50	74	41
SSP 16A	30.5	14.5	SSP 60	89	50
SSP 20A	34.5	18			
SSP 25A	41.5	22.5			
SSP 30A	46.5	27			
SSP 40A	63.5	35.6			
SSP 50A	79	44			
SSP 60A	89	53.5			
SSP 80	119	74			
SSP 80L					
SSP100	149	92			
SSP100L					

Figure B-11 NB mark Alignment

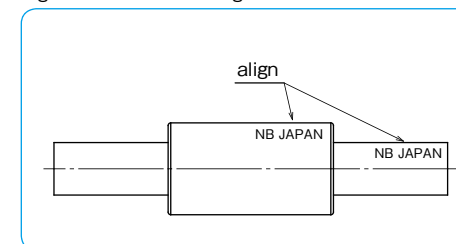
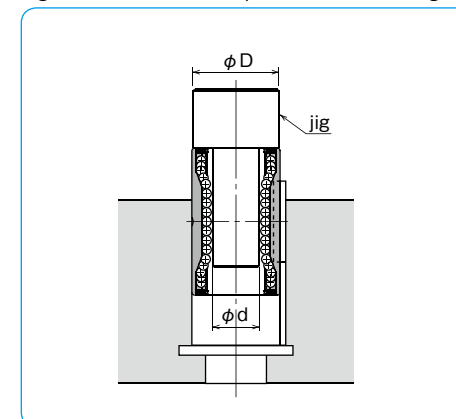

Table B-12 Fit for the Spline Nut

type of spline nut	clearance fit	transition fit
SSP	H7	J6
SSPM		

Figure B-12 Insertion of Spline Nut into Housing



Mounting of SSP Type

Examples of installing the SSP type are shown in Figures B-13 and B-14.

Figure B-13 Using a Retaining Ring

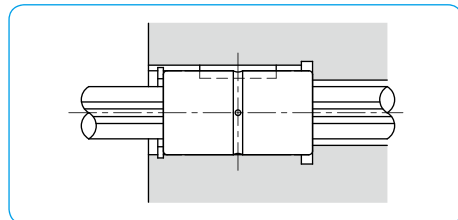
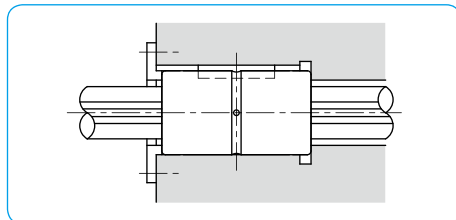

Figure B-14 Using a Push Plate



Key

The SSP type spline nut comes with a key shown in Figure B-15.

Figure B-15 Key for SSP Type

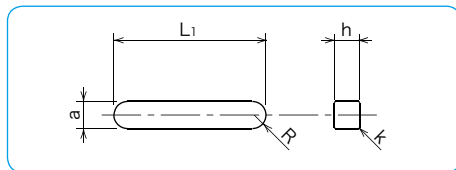

Table B-14 Major Dimensions of Key

part number	a		h		L <sub>1</sub>	R	k
	mm	tolerance μm	mm	tolerance μm			
SSP 4	2	+16 + 6	2	0 -25	6	1	0.2
SSP 6	2.5		2.5		10.5	1.25	
SSP 8	2.5		2.5		10.5	1.25	
SSP 10	3		3		13	1.5	
SSP 13A	3		3		15	1.5	
SSP 16A	3.5	+24 +12	3.5	0 -30	17.5	1.75	0.5
SSP 20A	4		4		29	2	
SSP 25A	4		4		36	2	
SSP 30A	4		4		42	2	
SSP 40A	6		6		52	3	
SSP 50A	8	+30/+15	7	0 -36	58	4	0.5
SSP 60A	12		8		67	6	0.8
SSP 80	16	+36 +18	10	-36	76	8	0.5
SSP 80L					110		
SSP100	20	+43 +22	13	0 -43	110	10	0.8
SSP100L					160		
SSP 20	4	+24	4	0	26	2	0.2
SSP 25	5	+12	5	-30	33	2.5	0.3
SSP 30	7	+30	7	0 -36	41	3.5	0.3
SSP 40	10	+15	8		55	5	0.5
SSP 50	15	+36	10	-36	60	7.5	0.5
SSP 60	18	+18	11	0/-43	68	9	0.5

Mounting of SSPM Type

Examples of installing the SSPM type are shown in Figures B-16 to B-19.

Figure B-16 Using F Type Lock Plates

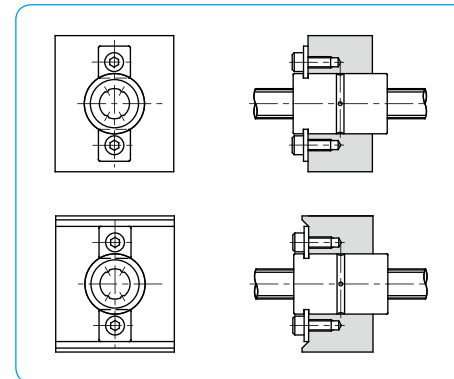

Figure B-17 Using LP Type Lock Plates

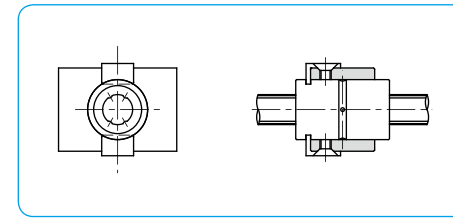

Figure B-19 Using Special Lock Plates (2)

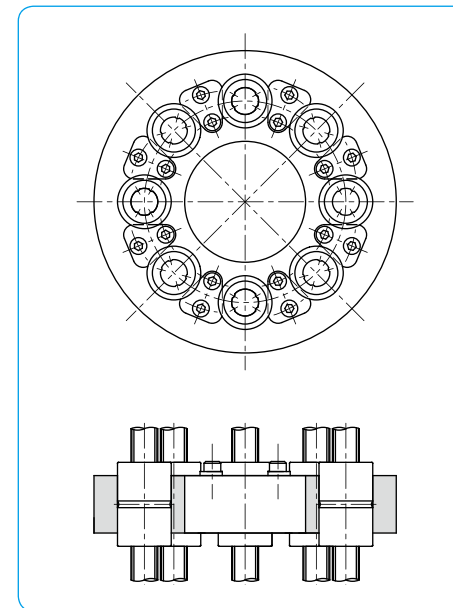
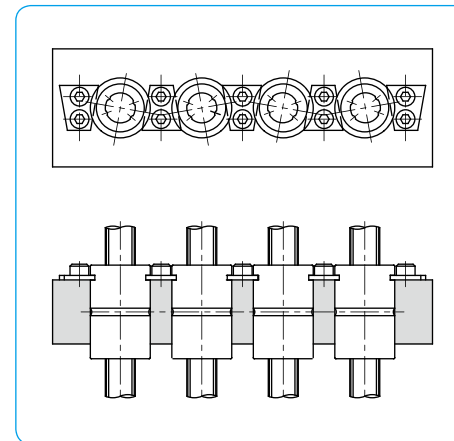

Figure B-18 Using Special Lock Plates (1)



F Type Lock Plate (Standard Plate)

The lock plate shown in Figure B-20 is provided with the SSPM spline nut.

Material: SUS304CSP

Table B-15 F Type Lock Plate

part number	K mm	G mm	t mm	R mm	applicable spline nut
FP 6	6.8	2.9	1.0	0.5	SSPM 6
FP 8	8.5	3.5	1.2	0.5	SSPM 8
FP10	8.5	3.5	1.2	0.5	SSPM10

Figure B-20 F Type Lock Plate

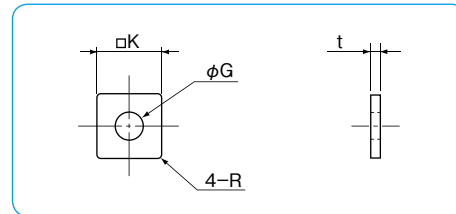

LP Type Lock Plate (Optional Plate)

The LP type lock plate is also available for purchase with the SSPM spline nut.

Material: SUS304CSP

Figure B-21 LP Type Lock Plate

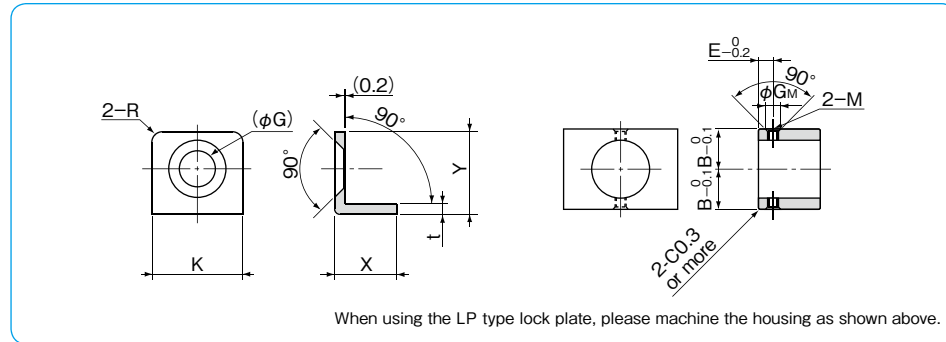

Table B-16 LP Type Lock Plate

part number	lock plate major dimensions						machined housing dimensions				applicable spline nut
	K mm	G mm	t mm	R mm	X mm	Y mm	B mm	E mm	GM mm	M	
LP 6	8.6	3.8	1.0	1	5.85	7.8	11.1	3.3	3.5	M2.5	SSPM 6
LP 8	9.15	4.5	1.2	1	6.45	9.2	12.3	4.0	4.2	M3	SSPM 8
LP10	9.15	4.5	1.2	1	6.45	9.2	14.8	4.0	4.2	M3	SSPM10

Mounting of SSPF Type

Examples of installing the SSPF type are shown in Figure B-22.

Figure B-22 Examples of installing SSPF Type

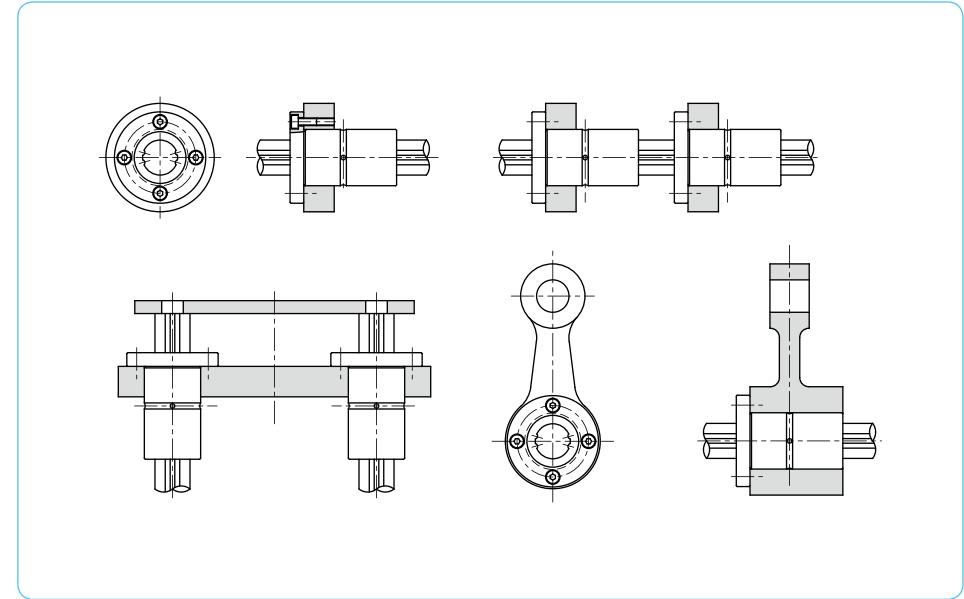

Mounting of SSPT Type

Examples of installing SSPT type are shown in Figure B-23.

Figure B-23 Examples of installing SSPT Type

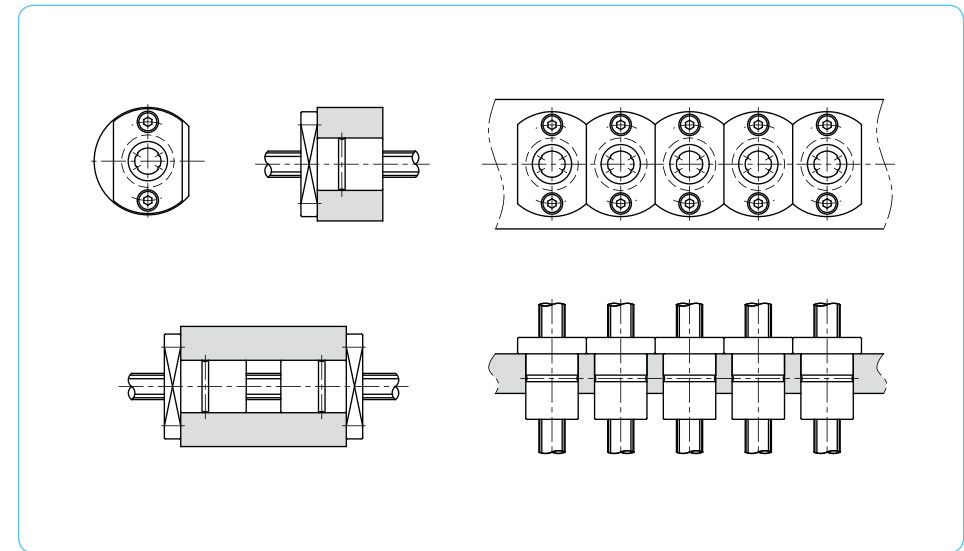



# ROTARY BALL SPLINE

The NB rotary ball spline can be used for both rotational motion and linear motion. The applications include SCARA robots, the vertical shaft of assembly equipment, tool changers, and loaders, etc.

## STRUCTURE AND ADVANTAGES

The NB Rotary Ball Spline nut consists of a spline nut and a rotating portion using either cross rollers for SPR or balls for SPB.

### High Accuracy

Ball Splines transfer torque and achieve accurate positioning in the linear direction. By adding rotating portion, Rotary Ball Splines can achieve accurate positioning in the linear and rotational directions.

### Half the Parts, Reduction in Installation Cost

The Spline nut and rotary bearing are combined in order to reduce the number of parts greatly, compared to the one for conventional system. The combination also reduces the housing thickness to a minimum, resulting in light weight and easy installation.

Figure B-24 Structure of SPR type

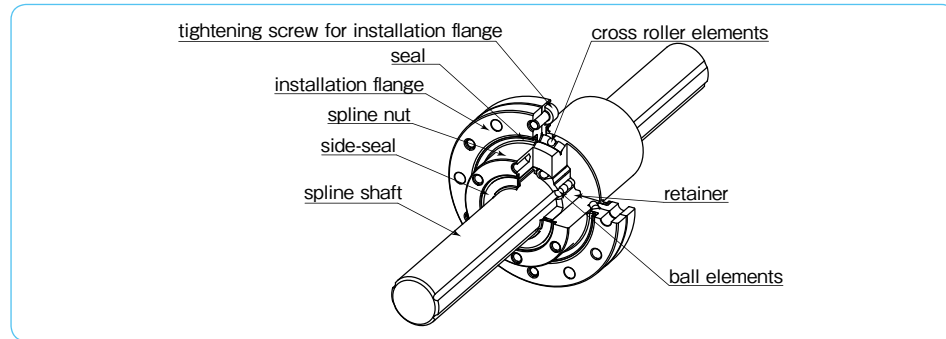
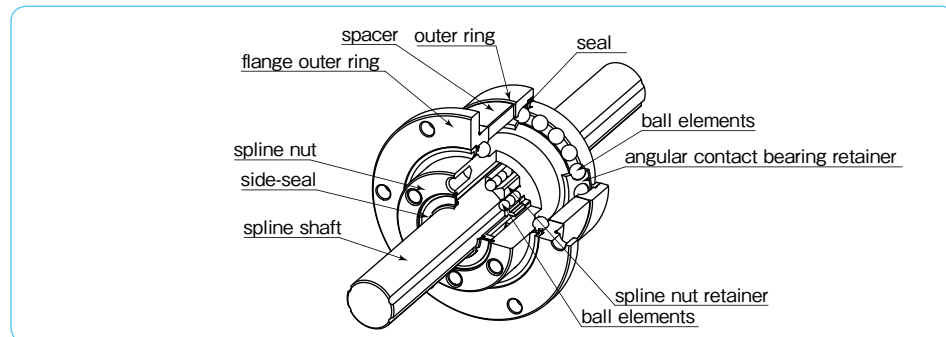

Figure B-25 Structure of SPB type



### Compact and High Rigidity (SPR type)

The cross rollers are directly attached to the ball spline's outer cylinder, resulting in a compact and light design.

SPR type has high rigidity despite its compactness. The tool changer is one of the typical applications.

### High Rigidity and High Speed (SPB type)

SPB type is a combination of a spline nut and angular contact bearings.

The rotary portion is a set of angular contact bearings which are aligned in the back-to-back duplex manner.

SPB type can bear radial, axial, and moment loads in a well-balanced way, thus best suited to high speed rotational applications.

## ACCURACY OF SPR TYPE

The accuracy of SPR type is measured at the points shown in Figure B-26.

Figure B-26 Accuracy Measurement Points

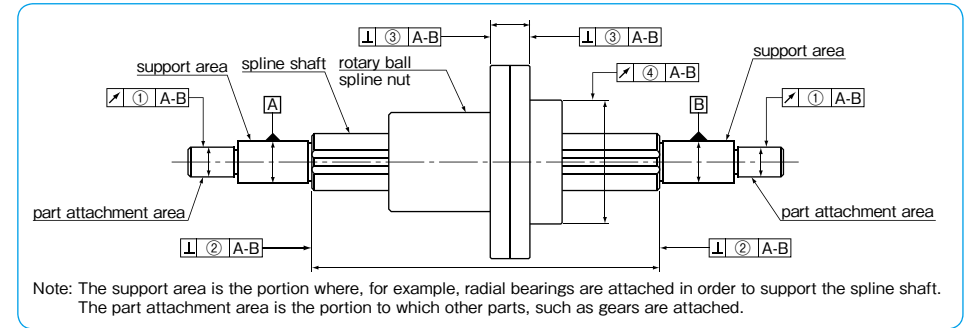

### Tolerance of Spline Shaft Groove Torsion (Max.)

The groove torsion is indicated per 100mm, arbitrarily set as the effective length of the spline shaft section.

Table B-17 Tolerance of Spline Shaft Groove Torsion (Max.)

tolerance
13 μm/100mm

Table B-18 Tolerance Relative to Spline Support Area (Max.)

part number	unit/μm		
	①radial runout of part attachment area	②perpendicularity of the end of the spline shaft section (when grinding is requested on the drawing)	③perpendicularity of the flange
SPR 6	14	9	14
SPR 8			
SPR10			
SPR13	19	11	18
SPR16			
SPR20A			
SPR25A	22	13	21
SPR30A			
SPR40A			
SPR50A	25	16	25
SPR60A			
SPR20			
SPR25			
SPR30			
SPR40	22	13	21
SPR50			
SPR60			
SPR50	25	16	25
SPR60			
SPR60A			
SPR60	29	19	29
SPR60A			
SPR60A			

Table B-19 ④Radial Runout of Outer Surface of Rotary Spline Nut Relative to Spline Support Area (Max.) unit/μm

spline shaft total length (mm)	part number							
	SPR 6, 8	SPR 10	SPR 13, 16	SPR 20A, 20, 25A, 25, 30A, 30	SPR 40A, 40, 50A, 50	SPR 60A, 60	SPR 60A, 60	SPR 60A, 60
greater than 200 or less 200	46	36	34	32	32	30	30	30
200 315	89	54	45	39	36	34	34	34
315 400	126	68	53	44	39	36	36	36
400 500	163*	82	62	50	43	38	38	38
500 630	—	102	75	57	47	41	41	41
630 800	—	—	92	68	54	45	45	45
800 1,000	—	—	115	83	63	51	51	51
1,000 1,250	—	—	153	102	76	59	59	59
1,250 1,600	—	—	195*	130	93	70	70	70
1,600 2,000	—	—	—	171	118	86	86	86

\*Please contact NB for spline shafts exceeding 2000mm. \* SPR6 shaft Max. length: 400mm SPR13, SPR16 Max.length: 1500mm

ACCURACY OF SPB TYPE

The accuracy of SPB type is measured at the points shown in Figure B-27.

Figure B-27 Accuracy Measurement Points

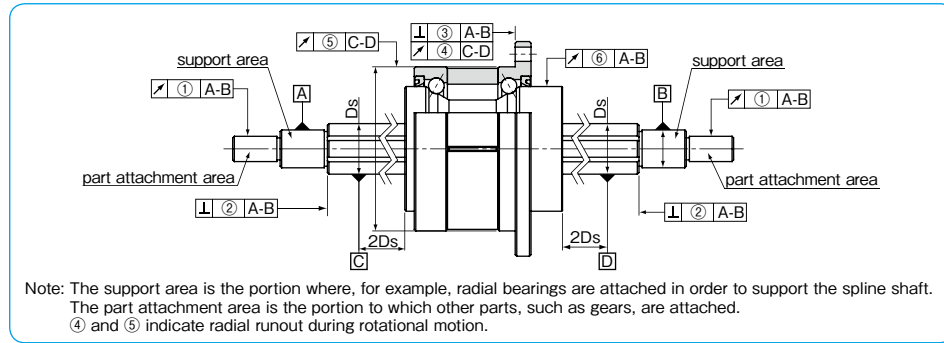

Tolerance of Spline Shaft Groove Torsion (Max.)

The groove torsion is indicated per 100mm, arbitrarily set as the effective length of the spline shaft section.

Table B-20 Tolerance of Spline Shaft Groove Torsion (Max.)

accuracy grade	high	precision (P)
tolerance	13μm/100mm	6μm/100mm

Table B-21 Tolerance Relative to Spline Support Area (Max.)

part number	①radial runout of part attachment area		②perpendicularity of the end of the spline shaft section (when grinding is requested on the drawing)		③perpendicularity of the flange	
	high-grade	precision-grade(P)	high-grade	precision-grade(P)	high-grade	precision-grade(P)
SPB16	19	12	11	8	18	13
SPB20						
SPB25	22	13	13	9	21	16

Table B-22 Radial Runout of Outer Surface of Rotary Spline Nut Relative to Spline Shaft Area(Max.) unit/μm

part number	④lateral runout of flange mounting side		⑤radial runout of outer ring	
	high-grade	precision-grade(P)	high-grade	precision-grade(P)
SPB16	18	13	21	16
SPB20				
SPB25	21	16		

Table B-23 ⑥Radial Runout of Spline Nut Relative to Spline Support Area(Max.) unit/μm

spline shaft total length (mm)		part number			
greater than	or less	SPB16		SPB20・25	
		high-grade	precision-grade(P)	high-grade	precision-grade(P)
—	200	34	18	32	18
200	315	45	25	39	21
315	400	53	31	44	25
400	500	62	38	50	29
500	630	75	46	57	34
630	800	92	58	68	42
800	1,000	115	75	83	52
1,000	1,250	153	97	102	65
1,250	1,600	195*	127*	130	85
1,600	2,000	—	—	171	116

\*SPB16 shaft maximum length : 1,500mm

\*\*Please contact NB for spline shafts exceeding 2000mm.

PRELOAD AND CLEARANCE

The amount of clearance and preload for the spline portion and the cross roller portion are expressed in terms of the clearance in the rotational direction and the clearance in the radial direction, respectively. Three levels of preload are available: standard, light (T1), and medium (T2).

Table B-24 Preload and Clearance in Rotational and Radial Direction unit/μm

	part number	standard	light (T1)	medium (T2)
linear motion	SPR 6	-2~+1	-6~-2	—
	SPR 8			
	SPR10			
	SPR13	-3~+1	-8~-3	-13~-8
	SPR16			
	SPR20A			
	SPR25A	-4~+2	-12~-4	-20~-12
	SPR30A			
	SPR40A			
	SPR50A	-6~+3	-18~-6	-30~-18
SPR60A				
rotational motion	SPR 6			
	SPR20			
	SPR25	-4~+2	-12~-4	-20~-12
	SPR30			
	SPR40			
	SPR50	-6~+3	-18~-6	-30~-18
SPR60				
	SPR 6 ~ SPR60		-1~+3	

Table B-25 Preload and Clearance in Rotational Direction (Linear Motion) unit/μm

part number	standard	light (T1)	medium (T2)
SPB16	-3~+1	-8~-3	-13~-8
SPB20			
SPB25	-4~+2	-12~-4	-20~-12

The preload is properly adjusted by the spacer for the angular contact bearings.

Table B-26 Operating Conditions and Preload

preload	symbol	operating conditions
standard	blank	minute vibration is applied. a precise motion is required. moment is applied in a given direction.
light	T1	light vibration is applied. light torsional load is applied. cyclic torque is applied.
medium	T2	shock/vibration is applied. over-hang load is applied. torsional load is applied.

SPECIAL REQUIREMENTS

NB provides customization such as shaft-end machining, spline nut machining, and surface treatment per customer requests. Table B-27 shows a list of recommended inner diameters for hollow spline shaft. Please contact NB for the inner diameter of SPR20~SPR60.

Figure B-28 Examples of Shaft-end Machining

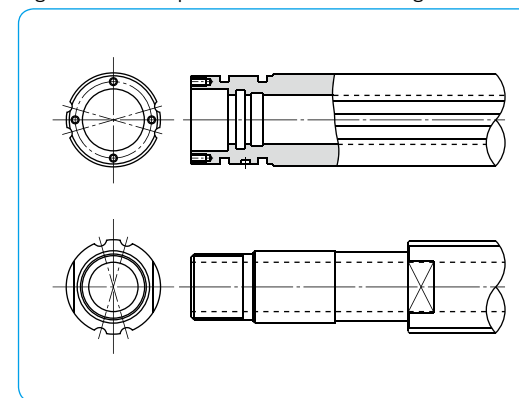
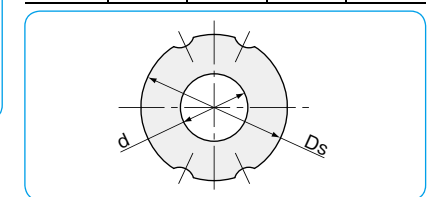

Table B-27 Recommended Inner Diameter for Hollow Spline Shaft

part number	outer diameter Ds mm	inner diameter d mm	cross-sectional coefficient Z mm	second moment of inertia I mm <sup>4</sup>
SPR 6	6	2	19.4	58
SPR 8	8	3	46.5	186
SPR10	10	4	89.6	448
SPR13	13	6	193	1,260
SPR16	16	8	348	2,780
SPR20A	20	10	686	6,860
SPR25A	25	15	1,230	15,400



MOUNTING

The flange attachment screws of SPR type have been pre-adjusted for smooth rotary movement and should never be loosened. Shock loading to the flange assembly should be avoided as this can degrade the accuracy of movement and deteriorate the overall performance. The spacer of SPB type is properly adjusted to produce the best preload condition. Shock loading to the spacer should be avoided as this can change the preload condition and deteriorate the accuracy.

Mounting of Rotary Ball Spline

When the flange of SPR type is to be used with a faucet joint (as shown in Figure B-29) the housing bore should be machined to a tolerance of H7 and to a minimum depth of 60% of the flange thickness. If only a light load is applied to the SPR in operation, the flange can be used without a pilot end. The housing bore for the SPB type should be machined to a tolerance of H7 and keep the enough depth so that the outer ring is inside the housing. If not, the outer ring may drop off. Please fix the mounting screws diagonally in steps with progressively applying more torque at each step. Please use a torque wrench for a uniform torque. The recommended torque values for medium-hardness steel screws are listed in Table B-28.

Insertion of Spline Shaft

When inserting the spline shaft into the rotary ball spline nut, ensure that the ball elements do not drop out. This is done by aligning the raceway grooves of the shaft with the rows of ball elements and the seal-lip of the nut. Then carefully insert the spline shaft through the spline nut.

LUBRICATION

Since NB rotary ball spline nuts are equipped with seals at both the spline portion and the rotational portion, the lubricant is retained for an extended period of time. The spline nut is prelubricated with lithium soap based grease prior to shipment for immediate use. Please relubricate with a similar type of grease periodically depending on the operating conditions. Low dust generation grease is available from NB standard grease. (refer to page Eng-39) However, an oil lubricant is recommended for high-speed applications. A grease fitting or machining oil holes is optional (Figure B-30,31), please contact NB for details.

Figure B-29 Flange Mounting Method

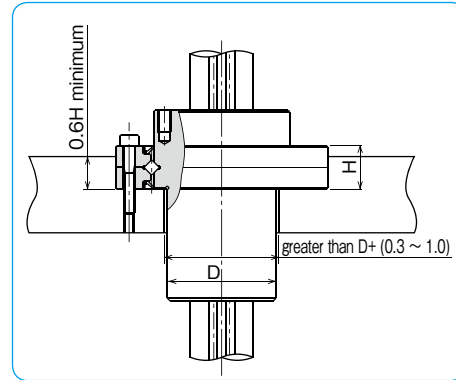

Table B-28 Recommended Torque unit / N·m

mounting screw	M2	M2.5	M3	M4	M5	M6	M8
recommended torque	0.4	0.9	1.4	3.2	6.6	11.2	27.6

(for alloy steel screw)

Figure B-30 Example of Installed Grease Fitting

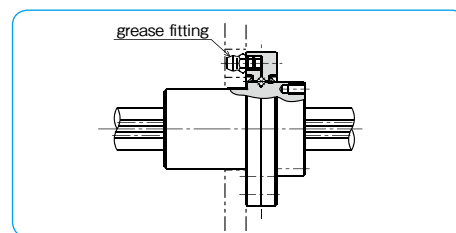
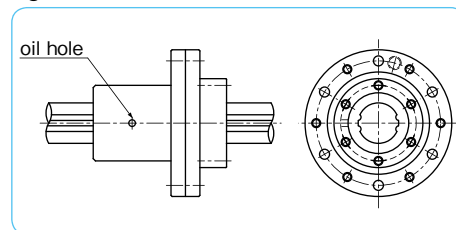

Figure B-31 Oil Hole



OPERATING CONDITIONS

The performance of the rotary ball spline is affected by the operating conditions of the application. The operating conditions should therefore be carefully taken into consideration.

Operating Temperature

Resin retainers are used in the rotary ball spline, so the operating temperature should never exceed 80°C.

Dust Prevention

Foreign particles or dust in the rotary ball spline nut affects the motion accuracy and shortens the life time. Standard seals will perform well for dust prevention under normal operating conditions, however, in a harsh environment it is necessary to attach bellows or protective covers.

APPLICATION EXAMPLES

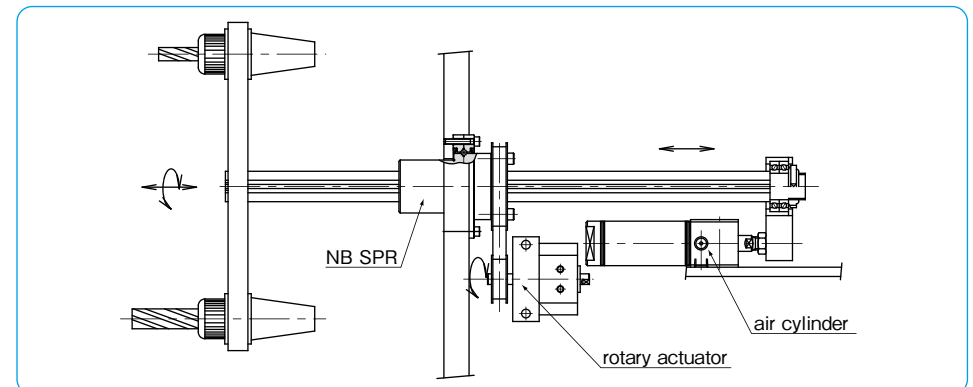
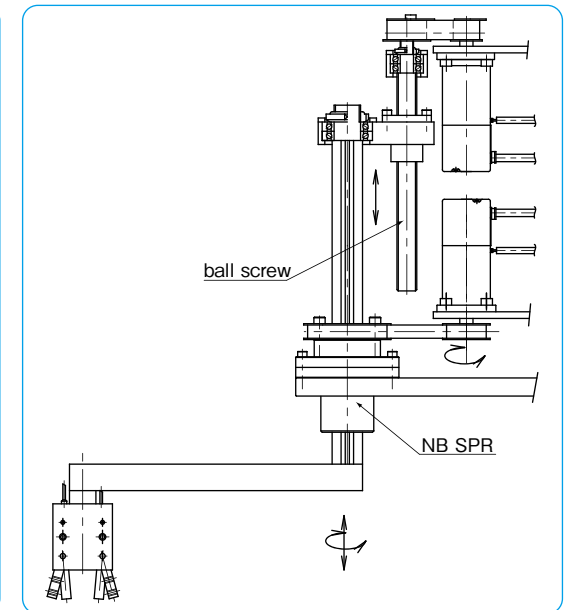
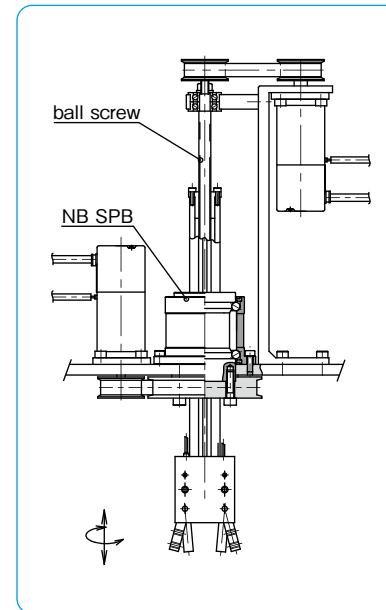

SPR TYPE

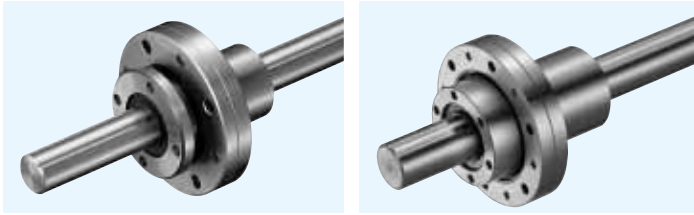

part number structure

example **SPR 25 - 2 - T1 - 436 / CU**

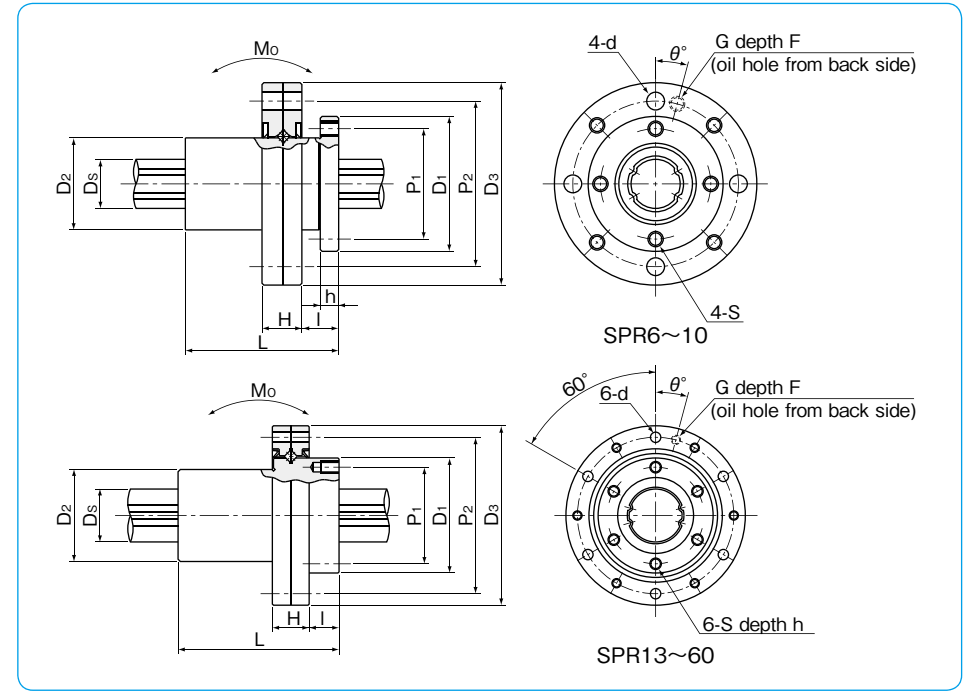
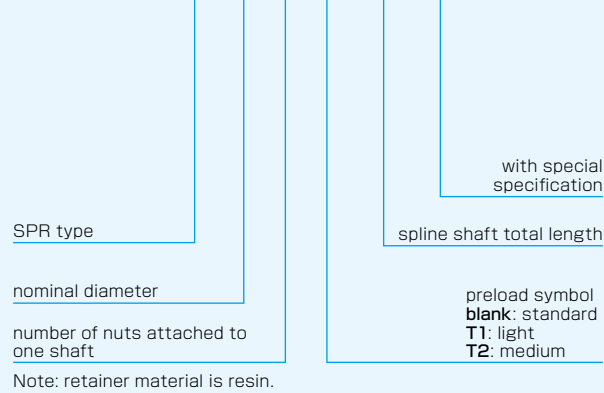

part number	major dimensions					major dimensions of cross roller bearing											
	D <sub>1</sub>	D <sub>2</sub>	L	P <sub>1</sub>	S	h	I	H	D <sub>3</sub>	P <sub>2</sub>	d	G	F	θ			
	mm μm	mm	mm	mm	mm	mm	mm	mm	mm	mm	mm	mm	mm	mm	°		
SPR 6	20		13	25		16	M2	2.5	5	6.5	30	0/-21	24	2.4	M3	2.6	20°
SPR 8	22	0	15	25	0	18	M2.5	3	6	6.5	33	0	27	2.9	M3	2.6	20°
SPR10	27	-21	19	33	0	22	M3	4	8	7	40	-25	33	3.4	M3	2.8	20°
SPR13	29		24	36	-0.2	24	M3	5	8	9	50		42	3.4	M3	3.6	15°
SPR16	36	0	31	50		30	M4	6	10	11	60	0	50	4.5	M3	4.4	15°
SPR20A	44	-25	35	63		38	M4	7	12	13	72	-30	62	4.5	M6×0.75	5.2	15°
SPR25A	55		42	71		47	M5	8	13	16	82		72	4.5	M6×0.75	6.4	15°
SPR30A	61	0	47	80	0	52	M6	10	17	17	100	0	86	6.6	M6×0.75	6.8	15°
SPR40A	76	-30	64	100	-0.3	66	M6	10	23	20	120	-35	104	9	M6×0.75	8	15°
SPR50A	92	0	80	125		80	M8	13	24	22	134	0	118	9	M6×0.75	8.8	15°
SPR60A	107	-35	90	140		95	M8	13	25	25	155	-40	137	9	M6×0.75	10	15°
SPR20	40	0	34	60	0/-0.2	34	M4	7	12	13	66	0	56	4.5	M6×0.75	5.2	15°
SPR25	50	-25	40	70		42	M5	8	13	16	78	-30	68	4.5	M6×0.75	6.4	15°
SPR30	61	0	47	80	0	52	M6	10	17	17	100	0	86	6.6	M6×0.75	6.8	15°
SPR40	76	-30	62	100	-0.3	64	M6	10	23	20	120	-35	104	9	M6×0.75	8	15°
SPR50	88	0	75	112		77	M8	13	24	22	130	0	114	9	M6×0.75	8.8	15°
SPR60	102	-35	90	127		90	M8	13	25	25	150	-40	132	9	M6×0.75	10	15°

Please contact NB for the grease fitting and relubrication method.

spline shaft	ball spline				cross roller bearing		allowable static moment Mo	mass		*maximum revolutions	size	
	D <sub>s</sub>	basic torque rating		basic load rating		dynamic		static	nut			shaft
	mm μm	C <sub>T</sub>	C <sub>0T</sub>	C	C <sub>0</sub>	C <sub>R</sub>		C <sub>0R</sub>	kg			kg/m
6	0/-12	1.5	2.4	1.22	2.28	0.6	0.5	5.1	0.04	0.21	2,940	<b>6</b>
8	0	2.1	3.7	1.45	2.87	1.2	1.10	7.4	0.05	0.38	2,580	<b>8</b>
10	-15	4.4	8.2	2.73	5.07	2.4	2.45	18.0	0.09	0.60	2,060	<b>10</b>
13	0	21	39.2	2.67	4.89	2.9	3.70	13.7	0.17	1.0	1,350	<b>13</b>
16	-18	60	110	6.12	11.2	5.6	6.70	46	0.33	1.5	1,080	<b>16</b>
20	0	105	194	8.9	16.3	6.55	8.79	110	0.57	2.4	890	<b>20A</b>
25	-21	189	346	12.8	23.4	9.63	12.7	171	0.81	3.7	700	<b>25A</b>
30	0	307	439	18.6	23.2	11.8	17.1	181	1.19	5.38	640	<b>30A</b>
40	0	674	934	30.8	37.5	23.0	32.3	358	2.25	9.55	510	<b>40A</b>
50	-25	1,290	2,950	40.3	64.9	27.8	44.0	690	3.57	15.0	430	<b>50A</b>
60	0/-30	1,570	2,620	47.7	79.5	29.0	48.8	881	5.03	21.6	370	<b>60A</b>
18.2	0	83	133	7.84	11.3	5.90	7.35	63	0.45	2.0	980	<b>20</b>
23	-21	162	239	12.3	16.1	9.11	11.5	104	0.75	3.1	770	<b>25</b>
28	0	289	412	18.6	23.2	11.8	17.1	181	1.25	4.8	640	<b>30</b>
37.4	0	637	882	30.8	37.5	23.0	32.3	358	2.30	8.6	510	<b>40</b>
47	-25	1,390	3,180	46.1	74.2	27.2	42.1	696	3.10	13.1	450	<b>50</b>
56.5	0/-30	2,100	4,800	58.0	127.4	26.5	42.6	1,300	4.70	19	400	<b>60</b>

\*Maximum revolutions for grease lubrication.

Contact NB for further information in case oil lubrication is required.

1kN=102kgf 1N·m=0.102kgf·m