

ROBUS IN-LINE HELICAL GEARBOX

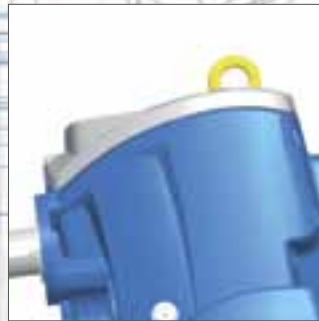

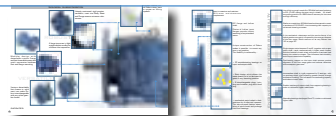

Technical characteristics pag. 2-3



List of components ROBUS-2
(2 reduction stages) pag. 4-5



List of components ROBUS-3
(3 reduction stages) pag. 6-7



Code system pag. 8

Kw / size / ratio pag. 9



Lubrication pag. 10

Technical data pag. 11



Technical data pag. 12

Performance table 25-30 pag. 13

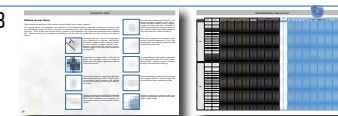

Performance table 30-35-40 pag. 14

Performance table 40-50 pag. 15

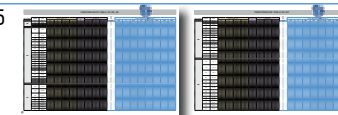

Performance table 50-60 pag. 16

Weights pag. 17



Dimensions pag. 18-19



Terms of sale and guarantee pag. 20



TECHNICAL CHARACTERISTICS



Uniquely contoured, rigid, precise, monobloc, cast iron Body, Base and Flange ensure extreme robustness.

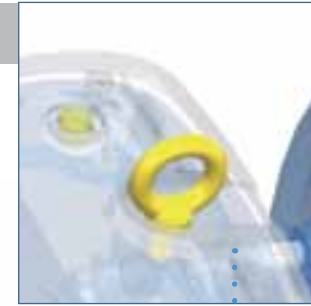

Except Robus 20, all Robus sizes have a screw-on lifting eyebolt



ROBUST

A large top cover in light weight aluminium alloy facilitates the inspection



Modular design with detachable output flange and foot base allows easy and quick conversion between foot and flange mounting



VERSATILE

Various detachable foot bases in solid cast iron make Robus interchangeable with any other gearbox brand

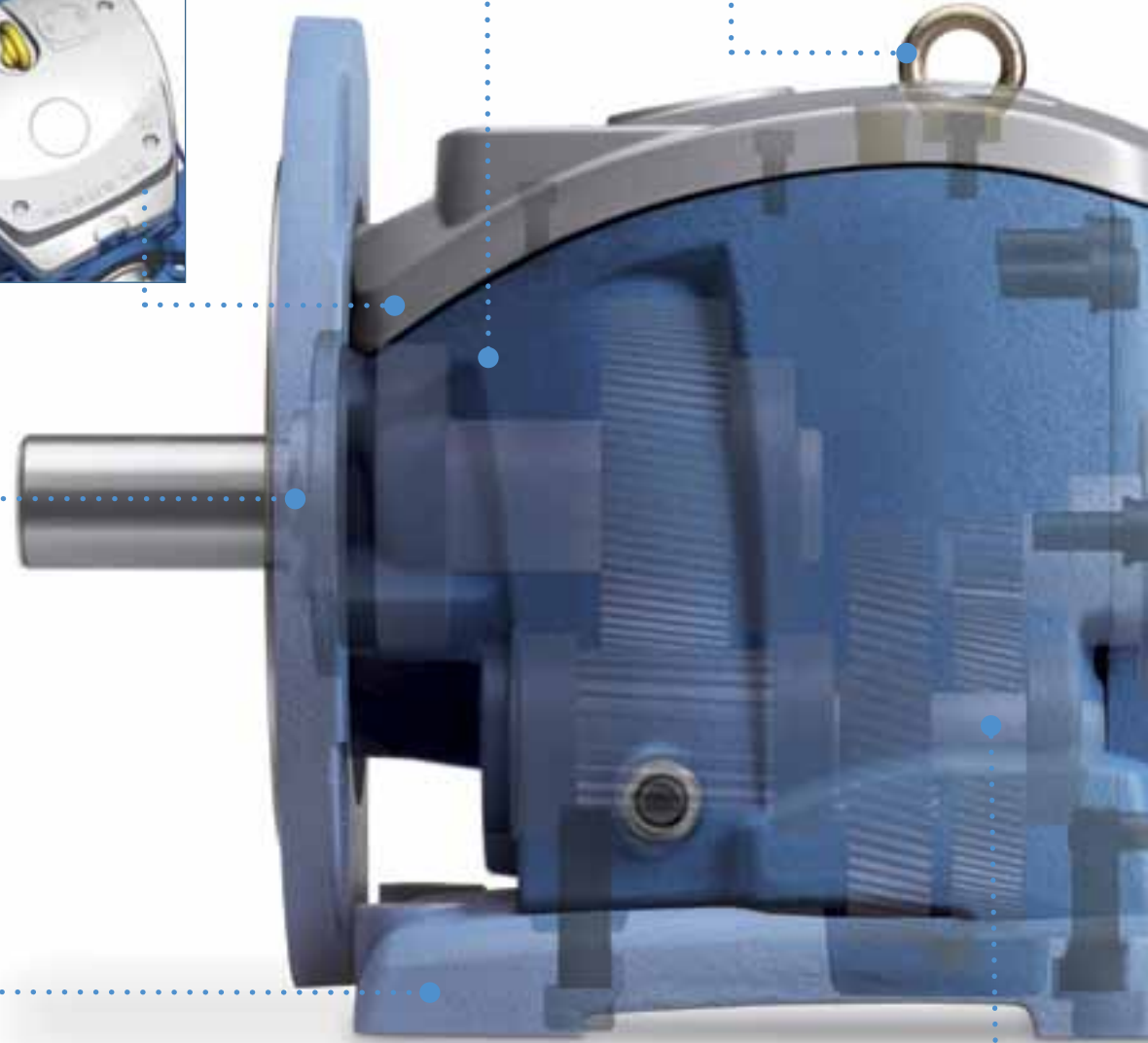

PATENTED



Easy to examine and maintain.
 Minimum maintenance requirement.
 All sizes are supplied with long-life synthetic oil.



IEC flange and hollow shaft.
 Choice of hollow input flanges permits direct mounting of any standard motor



Unique construction of Robus makes it possible to mount any size in any position.
 This flexibility is achieved by:

+ ZZ autolubricating bearings on input and output shaft

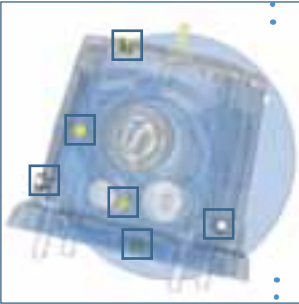

+ 6 interchangeable plugs, including one breather plug and a level plug



+ mechanical parts locked in their positions by snap rings and spacers. This also ensures better absorption of axial thrust and prolongs the life of bearings

FLEXIBLE MOUNTING

ENGINEERED FOR HIGHER RELIABILITY

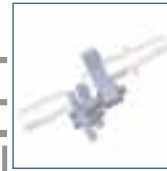

Use of high strength steels like 15CrMo4 and case hardening to 58 ±2 HRC reduce the wear rate in wheels. All wheels are profile ground to Din 3962 class 6 accuracy for low noise and high efficiency.



Shafts are made from 42CrMo4 steel and tempered to reach a hardness of 23-35 HRC, thus increasing their capacity to withstand shearing stresses.



If the mechanical robustness and the service factor of an helical gearbox are mainly influenced by the centres distance of the last stage, Robus confirms to be very robust (see "X2" at page 19)



Single stages ratios between 2 and 6, together with proper gears sizes, result mathematically in higher teeth number and size (module) of each wheel and a better fractioned load among the reduction stages. That influences both durability and torque transmission capability



Dual bearing support on the input shaft assures precise alignment of the first stage gears and reduces vibrations and consequent gear wear



Intermediate shaft is rigidly supported by 3 bearings, with no overhang wheel, thus imparting greater flexural strength and better meshing. This increases the overloading capacity and takes to lower noise



Smaller overhang distance of output shaft from supporting bearing in order to withstand higher radial loads



Abounding bearings size (pages 5 and 7), in order to withstand higher loads

LIST OF COMPONENTS ROBUS-2 (2 REDUCTION STAGES)

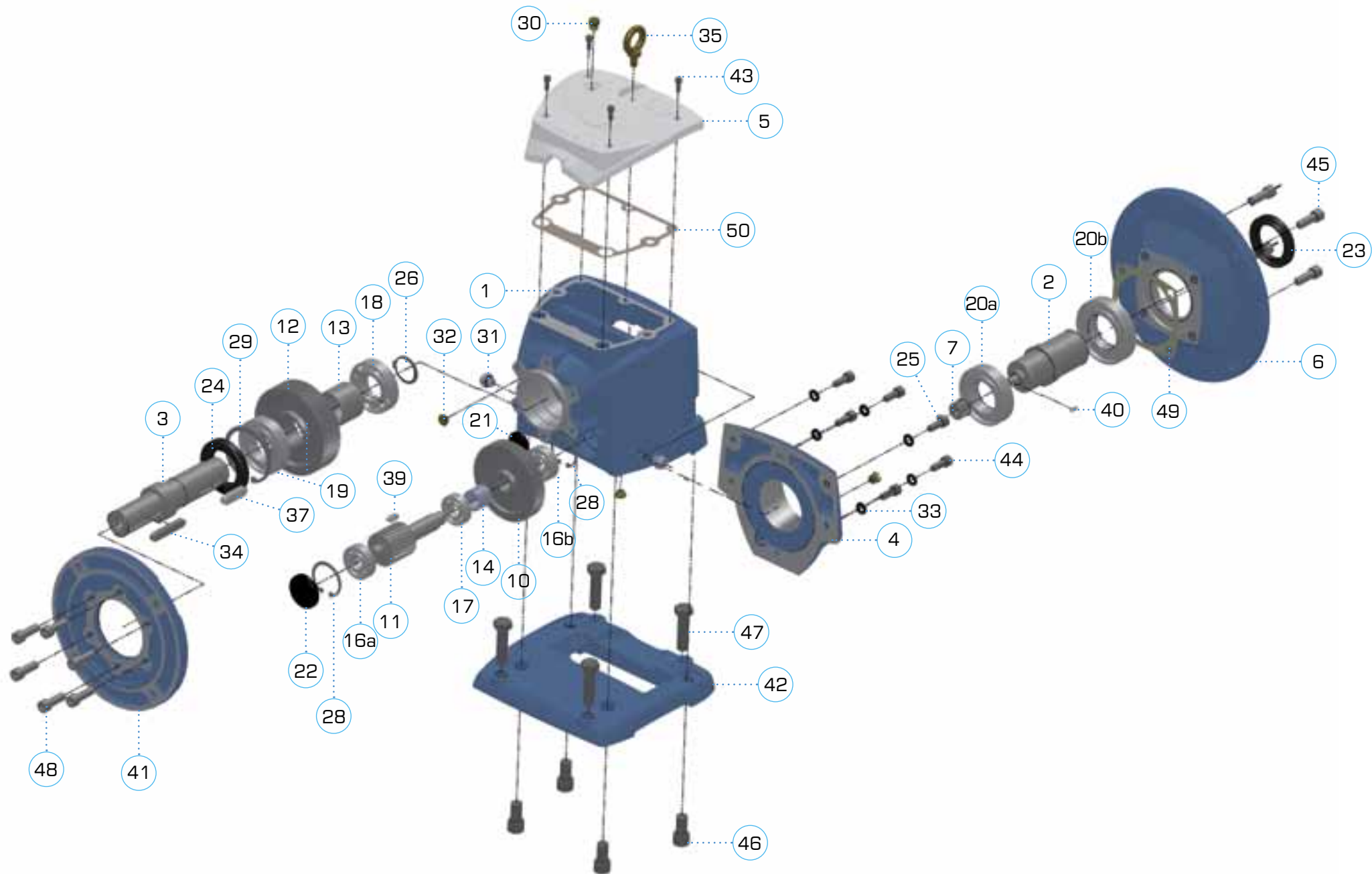

LIST OF COMPONENTS ROBUS-2 (2 REDUCTION STAGES)

		ROBUS25-2		ROBUS30-2		ROBUS35-2		ROBUS40-2		ROBUS50-2		ROBUS60-2	
item	code	description	q.ty	description	q.ty	description	q.ty	description	q.ty	description	q.ty	description	q.ty
1	HOU	housing	1	housing	1	housing	1	housing	1	housing	1	housing	1
2	ISH	input shaft	1	input shaft	1	input shaft	1	input shaft	1	input shaft	1	input shaft	1
3	OSH	output shaft	1	output shaft	1	output shaft	1	output shaft	1	output shaft	1	output shaft	1
4	ICV	input cover	1	input cover	1	input cover	1	input cover	1	input cover	1	input cover	1
5	TCV	top cover	1	top cover	1	top cover	1	top cover	1	top cover	1	top cover	1
6	IFL	input flange	1	input flange	1	input flange	1	input flange	1	input flange	1	input flange	1
		63B5		63		63		80		90		100/112	
		71B5		71		71		90		100/112		132	
		80B5		80		80		100/112		132		160	
		90B5		90		90		132		160		180	
				100/112		100/112							
7	P1	pinion 1	1	pinion 1	1	pinion 1	1	pinion 1	1	pinion 1	1	pinion 1	1
10	G2	gear 2	1	gear 2	1	gear 2	1	gear 2	1	gear 2	1	gear 2	1
11	P3	pinion 3	1	pinion 3	1	pinion 3	1	pinion 3	1	pinion 3	1	pinion 3	1
12	G3	gear 3	1	gear 3	1	gear 3	1	gear 3	1	gear 3	1	gear 3	1
13	SP	spacer	1	spacer	1	spacer	1	spacer	1	spacer	1	spacer	1
14	SP	spacer	1	spacer	1	spacer	1	spacer	1	spacer	1	spacer	1
16a	BEA	bearing 6202	1	bearing 6302	1	bearing 6304	1	bearing 6304	1	bearing 6306	1	Bearing 6307	1
16b	BEA	bearing 6202	1	bearing 6203	1	bearing 6204	1	bearing 6304	1	bearing 6306	1	Bearing 6307	1
17	BEA	bearing 6003	1	bearing 6004	1	bearing 6205	1	bearing 6205	1	bearing 6207	1	Bearing 6208	1
18	BEA	bearing 6205	1	bearing 7206	1	bearing 7207	1	bearing 7208	1	bearing 6210	1	Bearing 6212	1
19	BEA	bearing 6206ZZ	1	bearing 7207ZZ	1	bearing 7208ZZ	1	bearing 7209ZZ	1	bearing 6311ZZ	1	Bearing 6313-zz	1
20a	BEA							bearing 6210ZZ	1	bearing 6212ZZ	1	bearing 6215-zz	1
20b	BEA							bearing 6211ZZ	1	bearing 6213ZZ	1	bearing 6216-zz	1
20	BEA	bearing 6008ZZ	2	bearing 6009ZZ	2	bearing 6009ZZ	2			bearing 6009ZZ	2		
21	COV	plug seal D25	1	plug seal D30	1	plug seal D35	1	plug seal D35	1	plug seal D42	1	plug seal D52	1
22	COV	plug seal D35	1	plug seal D42	1	plug seal D52	1	plug seal D52	1	plug seal D72	1	plug seal D80	1
23	OS	oil seal 40x55x8	1	oil seal 45x60x9	1	oil seal 60x45x9	1	oil seal 55x80x10	1	oil seal 65x90x12	1	oil seal 80x105x13	1
24	OS	oil seal 62x35x11	1	oil seal 40x72x10	1	oil seal 50x80x10	1	oil seal 55x85x12	1	oil seal 65x120x15	1	oil seal 72x140x12	1
25	SNR	snap ring	1	snap ring	1	snap ring	1	snap ring	1	snap ring	1	snap ring	1
26	SNR	snap ring	1	snap ring	1	snap ring	1	snap ring	1	snap ring	1	snap ring	1
27	SNR	snap ring	2	snap ring	2	snap ring	2	snap ring	2	snap ring	2	snap ring	1
28	SNR	snap ring	2	snap ring	2	snap ring	2	snap ring	2	snap ring	2	snap ring	2
29	SNR	snap ring	1	snap ring	1	snap ring	1	snap ring	1	snap ring	1	snap ring	1
30	BPL	breather plug	1	breather plug	1	breather plug	1	breather plug	1	breather plug	1	breather plug	1
31	FPL	filler plug	6	filler plug	6	filler plug	6	filler plug	6	filler plug	6	filler plug	6
32	LPL	level plug	1	level plug	1	level plug	1	level plug	1	level plug	1	level plug	1
33	WSH	washer	4	washer	4	washer	4	washer	4	washer	4	washer	4
34	KEY	key	1	key	1	key	1	key	1	key	1	key	1
35	KEY	eye-bolt	1	eye-bolt	1	eye-bolt	1	eye-bolt	1	eye-bolt	1	eye-bolt	1
37	KEY	key	1	key	1	key	1	key	1	key	1	key	1
39	KEY	key	1	key	1	key	1	key	1	key	1	key	1
40	KEY	key	1	key	1	key	1	key	1	key	1	key	1
41	OFL	output flange	1	output flange	1	output flange	1	output flange	1	output flange	1	output flange	1
		200		200		250		300		350		450	
		160		160		200		250		300		350	
42	FSW	base	1	base	1	base	1	base	1	base	1	base	1
	FBF	SW		SW		SW		SW		SW		SW	
		BF		BF		BF		BF		BF		BF	
43	SCR	screw	6	screw	6	screw	6	screw	6	screw	6	screw	6
44	SCR	screw	6	screw	6	screw	6	screw	6	screw	6	screw	6
45	SCR	screw	4	screw	4	screw	4	screw	4	screw	4	screw	4
46	SCR	screw	4	screw	4	screw	4	screw	4	screw	4	screw	4
47	SCR	screw	4	screw	4	screw	4	screw	4	screw	4	screw	4
48	SCR	screw	6	screw	6	screw	6	screw	6	screw	6	screw	6
49	GK49	gasket	1	gasket	1	gasket	1	gasket	1	gasket	1	gasket	1
50	GK50	gasket	1	gasket	1	gasket	1	gasket	1	gasket	1	gasket	1

LIST OF COMPONENTS ROBUS-3 (3 REDUCTION STAGES)

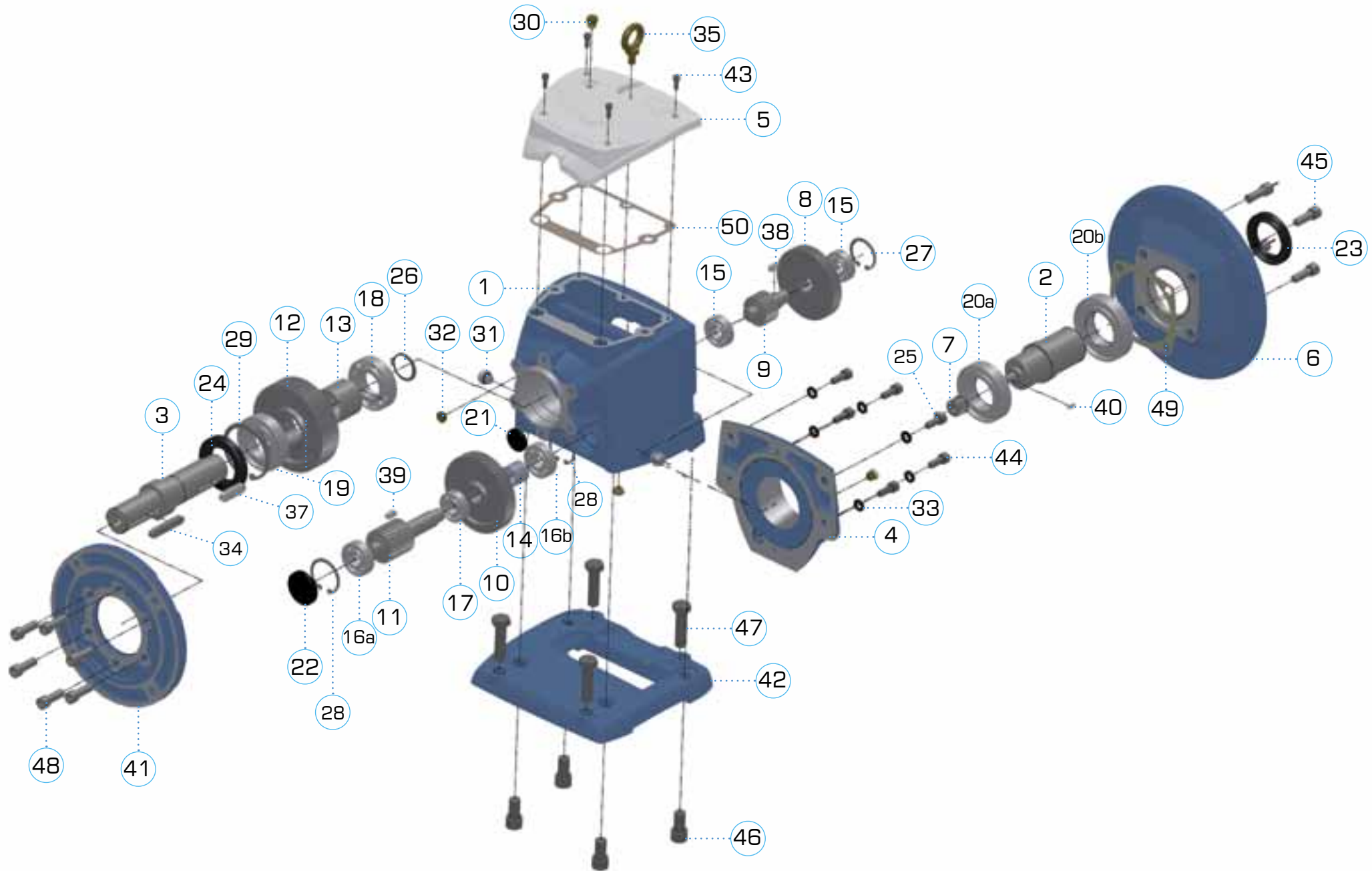

LIST OF COMPONENTS ROBUS-3 (3 REDUCTION STAGES)

		ROBUS25-3		ROBUS30-3		ROBUS35-3		ROBUS40-3		ROBUS50-3		ROBUS60-3	
item	code	description	q.ty	description	q.ty	description	q.ty	description	q.ty	description	q.ty	description	q.ty
1	HOU	housing	1	housing	1	housing	1	housing	1	housing	1	housing	1
2	ISH	input shaft	1	input shaft	1	input shaft	1	input shaft	1	input shaft	1	input shaft	1
3	OSH	output shaft	1	output shaft	1	output shaft	1	output shaft	1	output shaft	1	output shaft	1
4	ICV	input cover	1	input cover	1	input cover	1	input cover	1	input cover	1	input cover	1
5	TCV	top cover	1	top cover	1	top cover	1	top cover	1	top cover	1	top cover	1
6	IFL	input flange	1	input flange	1	input flange	1	input flange	1	input flange	1	input flange	1
		63B5		63		63		63		63		63	
		71B5		71		71		71		71		71	
		80B5		80		80		80		80		80	
		90B5		90		90		90		90		90	
				100/112		100/112		100/112		100/112		100/112	
7	P1	pinion 1	1	pinion 1	1	pinion 1	1	pinion 1	1	pinion 1	1	pinion 1	1
8	G1	gear 1	1	gear 1	1	gear 1	1	gear 1	1	gear 1	1	gear 1	1
9	P2	pinion 2	1	pinion 2	1	pinion 2	1	pinion 2	1	pinion 2	1	pinion 2	1
10	G2	gear 2	1	gear 2	1	gear 2	1	gear 2	1	gear 2	1	gear 2	1
11	P3	pinion 3	1	pinion 3	1	pinion 3	1	pinion 3	1	pinion 3	1	pinion 3	1
12	G3	gear 3	1	gear 3	1	gear 3	1	gear 3	1	gear 3	1	gear 3	1
13	SP	spacer D30.5xL24	1	spacer D35.5xL32.5	1	spacer D40.5xL36.6	1	spacer	1	spacer D55.5xL45	1	spacer D65.5xL50	1
14	SP	spacer D20xL22	1	spacer D20.5xL23.5	1	spacer D21.5xL24.5	1	spacer	1	spacer D35xL32	1	spacer D40.5xL38	1
15	BEA	bearing 6002	2	bearing 6003	2	bearing 6203	2	bearing 6204	2	bearing 6206	2	Bearing 6207	2
16a	BEA	bearing 6202	1	bearing 6302	1	bearing 6304	1	bearing 6304	1	bearing 6306	1	Bearing 6307	1
16b	BEA	bearing 6202	1	bearing 6203	1	bearing 6204	1	bearing 6304	1	bearing 6306	1	Bearing 6307	1
17	BEA	bearing 6003	1	bearing 6004	1	bearing 6205	1	bearing 6205	1	bearing 6207	1	Bearing 6208	1
18	BEA	bearing 6205	1	bearing 7206	1	bearing 7207	1	bearing 7208	1	bearing 6210	1	Bearing 6212	1
19	BEA	bearing 6206	1	bearing 7207ZZ	1	bearing 7208ZZ	1	bearing 7209ZZ	1	bearing 6311ZZ	1	Bearing 6313ZZ	1
20a	BEA							bearing 6210ZZ	1	bearing 6212ZZ	1	bearing 6215ZZ	1
20b	BEA							bearing 6211ZZ	1	bearing 6213ZZ	1	bearing 6216ZZ	1
20	BEA	bearing 6008	2	bearing 6009ZZ	2	bearing 6009ZZ	2	bearing 6009ZZ	2	bearing 6009ZZ	2	bearing 6009ZZ	2
21	COV	plug seal D25	1	plug seal D30	1	plug seal D35	1	plug seal D35	1	plug seal D42	1	plug seal D52	1
22	COV	plug seal D35	1	plug seal D42	1	plug seal D52	1	plug seal D52	1	plug seal D72	1	plug seal D80	1
23	OS	oil seal 40x55x8	1	oil seal 45x60x9	1	oil seal 60x45x9	1	oil seal 55x80x10	1	oil seal 65x90x12	1	oil seal 80x105x13	1
24	OS	oil seal 35x62x11	1	oil seal 40x72x10	1	oil seal 50x80x10	1	oil seal 55x85x12	1	oil seal 65x120x15	1	oil seal 72x140x12	1
25	SNR	snap ring	1	snap ring	1	snap ring	1	snap ring	1	snap ring	1	snap ring	1
26	SNR	snap ring	1	snap ring	1	snap ring	1	snap ring	1	snap ring	1	snap ring	1
27	SNR	snap ring	2	snap ring	2	snap ring	2	snap ring	2	snap ring	2	snap ring	1
28	SNR	snap ring	2	snap ring	2	snap ring	2	snap ring	2	snap ring	2	snap ring	2
29	SNR	snap ring	1	snap ring	1	snap ring	1	snap ring	1	snap ring	1	snap ring	1
30	BPL	breather plug	1	breather plug	1	breather plug	1	breather plug	1	breather plug	1	breather plug	1
31	FPL	filler plug	6	filler plug	6	filler plug	6	filler plug	6	filler plug	6	filler plug	6
32	LPL	level plug	1	level plug	1	level plug	1	level plug	1	level plug	1	level plug	1
33	WSH												
34	KEY	key	1	key	1	key	1	key	1	key	1	key	1
35	KEY	eye-bolt	1	eye-bolt	1	eye-bolt	1	eye-bolt	1	eye-bolt	1	eye-bolt	1
37	KEY	key	1	key	1	key	1	key	1	key	1	key	1
38	KEY	key	1	key	1	key	1	key	1	key	1	key	1
39	KEY	key	1	key	1	key	1	key	1	key	1	key	1
40	KEY	Key	1	Key	1	Key	1	Key	1	Key	1	Key	1
41	OFL	output flange	1	output flange	1	output flange	1	output flange	1	output flange	1	output flange	1
		200		200		250		300		350		450	
		160		160		200		250		300		350	
42		base	1	base	1	base	1	base	1	base	1	base	1
	FSW	SW		SW		SW		SW		SW		SW	
	FBF	BF		BF		BF		BF		BF		BF	
43	SCR	screw	6	screw	6	screw	6	screw	6	screw	6	screw	6
44	SCR	screw	6	screw	6	screw	6	screw	6	screw	6	screw	6
45	SCR	screw	4	screw	4	screw	4	screw	4	screw	4	screw	4
46	SCR	screw	4	screw	4	screw	4	screw	4	screw	4	screw	4
47	SCR	screw	4	screw	4	screw	4	screw	4	screw	4	screw	4
48	SCR	screw	6	screw	6	screw	6	screw	6	screw	6	screw	6
49	GK49	gasket	1	gasket	1	gasket	1	gasket	1	gasket	1	gasket	1
50	GK50	gasket	1	gasket	1	gasket	1	gasket	1	gasket	1	gasket	1

CODE SYSTEM

- 1 first 4 digits describe the ROBUS size
RB40 =ROBUS 40
RB50 =ROBUS 50
 etc



- 2 then 1 digit tell the nr of stages
2 =2 stages
3 =3 stages

- 3 then 3 digits are the rated ratio
020 =i:20
120 =i:120
 etc



- 4 then 3 digits for the mounting type

FSW =base type SW (page19)
FBF =base type BF (page19)

140 =output flange 63B5 KP=140
160 =output flange 71B5 KP=160
200 =output flange 80/90B5 KP=200
250 =output flange 100/112B5 KP=250
300 =output flange 132B5 KP=300
350 =output flange 160/180 KP=350
450 =output flange 200 KP=450

UNV =without foot or output flange

- 5 than 3 digits for the input flange (that determines the input hole diameter too)

714 =71B14 (page18)
805 =80B5 (page18)
905 =90B5 (page18)
125 =100-112B5 (page18)
135 =132B5 (page18)
 etc ...

For instance:

RB603070FSW135

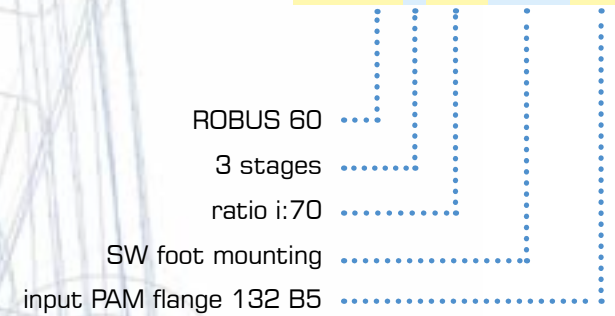
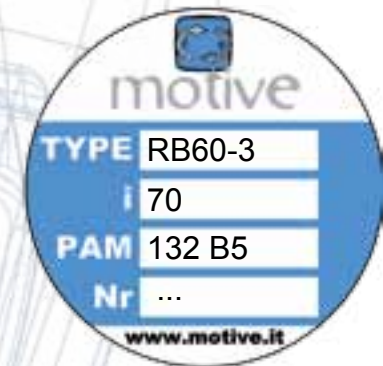

Plate:



KW / SIZE / RATIO

service factor $f_s \geq 1.5$

input PAM	63			71			80			90			100/112			132			160		180				
	11 mm			14 mm			190 mm			24 mm			28 mm			38 mm			42 mm		48 mm				
	P_{n1} kW	P_{n1} Hp		P_{n1} kW	P_{n1} Hp		P_{n1} kW	P_{n1} Hp		P_{n1} kW	P_{n1} Hp		P_{n1} kW	P_{n1} Hp		P_{n1} kW	P_{n1} Hp		P_{n1} kW	P_{n1} Hp		P_{n1} kW	P_{n1} Hp		
120																								120	
110																									110
100			25	25											60										100
90																									90
80																									80
70																									70
60																									60
55																									55
50																									50
45																									45
40	20	20																							40
35			20	20																					35
30																									30
25																									25
20					20																				20
15						20																			15
10							20	20																	10
5									20																5

= 3 stages

= 2 stages

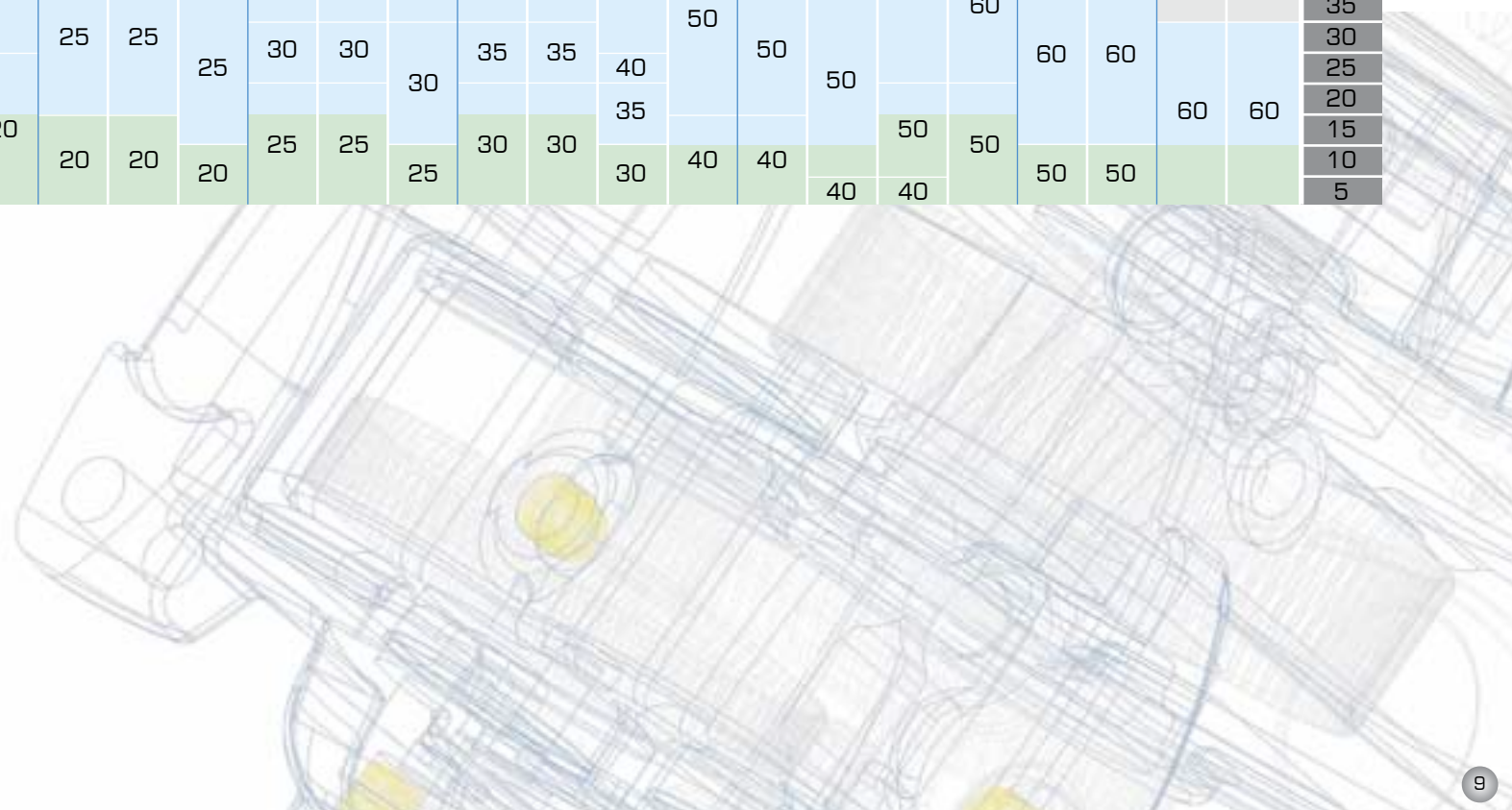

LUBRICATION

Each Robus is supplied with long-life synthetic oil and do not require any maintenance.
The oil quantity is suitable for B3 mounting position

ROBUS	oil (lt)						ISO	temp.	oil type	
	B3	B6	B7	B8	V5	V6				
20	0,25	0,4	0,35	0,55	0,55	0,35	VG 220	-25 +80°C	Mobil Glygoyle 30	Shell Tivela S220
25	0,3	0,75	0,95	0,95	1,05	0,85				
30	0,7	1,5	1,5	1,5	2,2	1,6				
35	1,1	1,8	2	2	1,8	1,6				
40	1,2	2,5	3,4	3,4	4,1	3,8				
50	2,3	6,3	6,5	6,5	7,7	6,7				
60	4,6	11,3	11,7	11,7	13,4	11,7				

After adapting the oil quantity, each Robus can be mounted in ANY position, thus giving big advantages in the stock management and lead time, thanks to the following 3 characteristics:



1 ZZ autolubricating bearings on input and output shaft

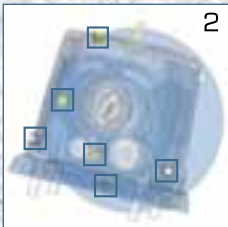

2 6 interchangeable plugs, including one breather plug and a level plug. Level and breather plug must be positioned according to this chart



3 mechanical parts locked in their positions by circlips and spacers. This also ensures better absorption of axial thrust and prolongs the life of bearings

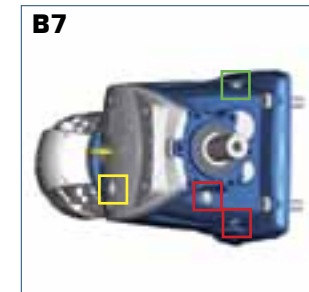
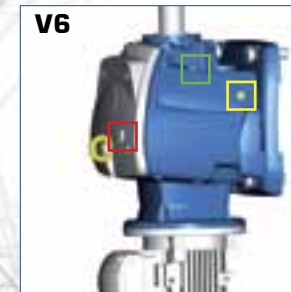
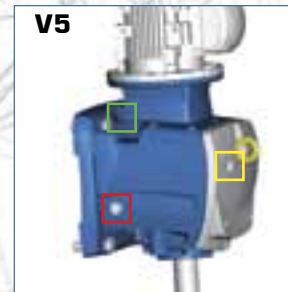
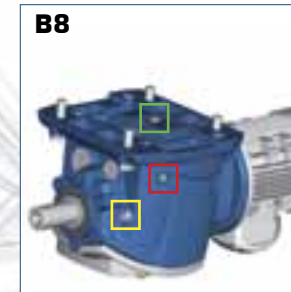
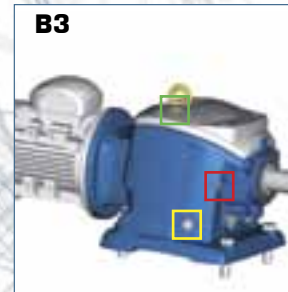

breather plug



level plug



filler plug

Rated output torque M_{n2} [Nm]

Torque output transmissible under uniform loading and referred to the input speed n_1 and the corresponding output speed n_2 .

The output torque can be calculated with the following formula:

$$M_{n2} = \frac{P_{n1} \text{ [kW]} \cdot 9550}{n_2} \cdot \eta$$

Torque demand M_{r2} [Nm]

Torque calculated based on application requirements. It must be $\leq M_{n2}$ of the chosen BOX unit.

Input power P_{n1} [kW]

This is the power value of the motor applied to the input shaft and corresponding to a certain input speed n_1 , a service factor $f_s = 1$ and a duty service S_1 .

It is even possible to calculate the motor-size necessary by using the formula:

$$P_{n1} \text{ [kW]} = \frac{M_{r2} \cdot n_2}{9550 \cdot \eta}$$

Since the value calculated in this way could not really correspond to an input power actually available in the IEC standardised motors, it will be necessary to choose, among the input powers available, the one which is immediately higher, checking this in the Motive catalogue of the motors.

Efficiency η [%]

An inherent factor in the selection worm-gear boxes is the efficiency η , defined as the ratio between the mechanical power coming out from the output shaft, and the power in the input shaft:

$$\eta = \frac{P_{n2}}{P_{n1}}$$

The efficiency in helical gearboxes is mainly determined by the gearing and

bearing friction.

The efficiency of ROBUS varies with the nr of stages: it's 94% when the reduction stages are 3, 96% when the stages are 2.

The starting efficiency is always less than the efficiency at rated speed

Gear ratio i

It is the relationship of the input speed n_1 and the output speed n_2

$$i = \frac{n_1}{n_2}$$

In the combined, the total ratio is the result of the product of the ratio of the two single boxes.

Input speed n_1 [rpm]

It is the speed the BOX unit is driven at.

Output speed n_2 [rpm]

It is the rotation speed of the output shaft.

Service factor f_s

It is a numeric value describing the BOX unit service duty. With unavoidable approximation, it takes into consideration:

- the daily working hours **h/d**
- the load classification (see table 2), and then the moment of inertia of the driven masses.
- The number of starts per hour **s/h**
- The presence of brake motors, for which it is necessary to multiply for 1.12 the service factor value deducted by the graph 2.
- The significance of the application in terms of safety, for example lifting of parts

In the graph 2, the service factor f_{sr} required by a certain application can be attained, after having selected the proper "daily working hours" (h/d) column, by intersecting the number of starts per hour (s/h) and one of the a, b or c curves. The curves a, b and c are linked with the load classification described in the table 2.

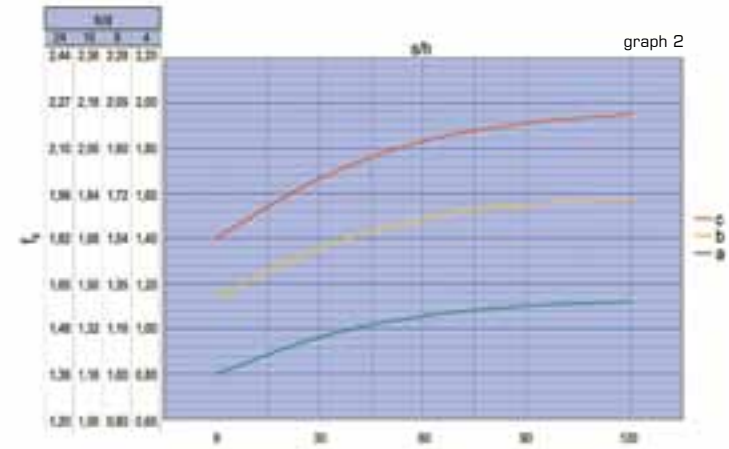

tab. 2

load classification	application
c uneven operation, heavy loads, larger masses to be accelerated	conveyors with violent jerks; compressors ad alternate pumps with 1 or more cylinders; machinery for bricks, tiles and clay; kneaders; milling machines; lifting winches with buckets; rotting furnaces; heavy fans or mining purposes; mixers for heavy materials; machine-tools; planing kinds; alternating saws; shears; tumbling barrels; vibrators; shredders; turntables
b starting with moderate loads, uneven operating conditions, medium size masses to be accelerated	belt conveyors with varied load with transfer of bridge trucks for light duty; levelling machines; shakers and mixed for liquid with variable density and viscosity; machines for the food industry (kneading troughs, mincing machines, slicing machines, etc); sifting machines for sand gravel; textile industry machines; cranes, hoists, goodstifts; fertilizer scrapers; concrete mixers; folding machines; winches; crane mechanisms
a easy starting, smooth operation, small masses be accelerated	belt conveyors for light material; centrifugal pumps; rotary gear pumps; screw feeders for light materials; lifts; bottling machines; auxiliary controls of tool machines; fans; power generators; fillers; small mixers

If, after the selection of the right M_{r2} and n_2 in the following performance tables, you don't find a BOX unit whose service factor f_s is \geq of the requested one f_{sr} , you can choose a BOX unit in which $M_{n2} > M_{r2}$. In fact, in order to satisfy f_{sr} , you can choose another BOX unit whose output torque is $\geq M_{c2}$ output torque, where:

$$M_{c2} = M_{r2} \cdot f_{sr}$$

Note: This rule is valid only if the new BOX unit that has been selected in this way has a service factor $f_s \geq 1$ in the performance tables.

From another point of view, the value of f_s in the performance tables refers to a case in

which the effective torque requested by the application M_{r2} matches perfectly with the one appearing on the catalogue M_{n2} . Whenever the torque indicated in the performance table is higher than the requested one, the offered service factor of the performance table can be increased according to the formula:

$$f_{s \text{ real}} = \frac{f_s \text{ on the table} \cdot M_{n2} \text{ on the table}}{M_{r2}}$$

The value of f_s calculated in this way must be $\geq f_{sr}$.

Offered service factor

Which features determine the service factor offered by an helical gearbox?

The service factor of a gearbox is its capacity to withstand operating load and overloads, a certain number of starts, the duration of operating time, and mechanical shocks and vibrations. Thus, higher the service factor, greater is the possibility of trouble-free operation and increased life. Without aiming to be completely exhaustive, we list here the main features that influence the service factor:

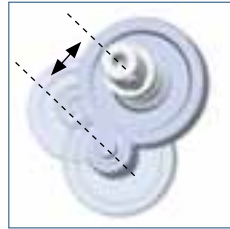

Amongst all parts, the last stage gears are subjected to highest mechanical stresses. Higher centre distance which in turn results in higher module considerably increases the service factor. ROBUS excels in the area (see measures at page 22)



Compared to fractioned or Aluminium body, the monobloc cast-iron body of ROBUS provides higher rigidity and mechanical robustness.



Use of high strength steels like 15CrMo4 and case hardening to 58 ± 2 HRC reduce the wear rate in wheels. All wheels are profile ground to Din 3962 class 6 accuracy



Shafts are made from 42CrMo4 steel and tempered to reach a hardness of 23-35 HRC, thus increasing their capacity to withstand shearing stresses and torsion effect.



Optimal ratios (between 2 and 6) in the several stages, together with appropriate centre distances, result in higher number of teeth and size (module) of each wheel and better torque transmission fractioning through various stages. This improves the overall durability.



Dual bearing support on the input shaft ensures precise alignment of the first stage gears and reduces vibrations and consequent gear wear



An intermediate shaft rigidly supported by 3 bearings instead of 2, with no overhang wheel, imparts greater flexural strength and smoother meshing



Oversized bearings (see ROBUS bearings list at pages 5 and 7), allow the gearbox to withstand higher operating loads



Mechanical parts locked in their position by snap rings and spacers. This ensures better absorption of axial thrust and prolongs the life of bearings



Smaller overhang of output shaft from supporting bearing in order to withstand higher radial loads

PERFORMANCE TABLE 25-30



rpm n ₁ =1450		rated ratio i:	real ratio i:	input power P _{n1}				fs	output P _{n2}			stages	input connection B5 IEC 72-1						
ROBUS				kW	Hp	motore	n ₁ [rpm]		n ₂ [rpm]	M ₂ [Nm]	M ₂ [Kgm]		63	71	80	90	100/112	132	160
25	120	119,93	0,13	0,18	71B-8	651	1,37	5,8	200	20,2									
			0,18	0,25	71A-6	910	1,31	7,9	204	20,6									
			0,25	0,35	71A-4	1400	1,32	11,7	192	19,4									
	110	106,18	0,13	0,18	71B-8	651	1,49	6,1	190	19,2									
			0,18	0,25	71A-6	910	1,42	8,6	189	19,0									
			0,37	0,5	71B-4	1400	1,01	13,2	252	25,4									
	100	96,44	0,37	0,5	71B-4	1400	1,26	14,5	229	23,1									
	90	91,47	0,55	0,75	80A-4	1400	1,20	15,3	323	32,5									
	80	79,29	0,55	0,75	80A-4	1400	1,34	17,7	280	28,2									
	70	69,57	0,55	0,75	80A-4	1400	1,50	20,1	245	24,8									
	60	59,94	0,75	1	80B-4	1400	1,10	20,1	335	33,8									
			0,75	1	80B-4	1400	1,26	23,4	288	29,1									
			0,75	1	80B-4	1400	1,46	24,5	275	27,8									
	55	57,2	1,1	1,5	80C-4	1400	1,00	24,5	403	40,7									
	50	49,28	0,75	1	80B-4	1400	1,64	28,4	237	23,9									
			1,1	1,5	90S-4	1400	1,12	28,4	348	35,1									
			0,75	1	80B-4	1400	1,68	30,4	222	22,4									
	45	46,07	1,1	1,5	90S-4	1400	1,15	30,4	325	32,8									
	40	39,27	0,75	1	80B-4	1400	1,94	35,7	189	19,1									
			1,1	1,5	90S-4	1400	1,32	35,7	277	27,9									
			1,1	1,5	90S-4	1400	1,68	43,1	229	23,1									
	35	32,51	1,5	2	90L-4	1410	1,23	43,4	310	31,3									
	30	30,18	1,1	1,5	90S-4	1400	1,68	46,4	213	21,5									
			1,5	2	90L-4	1410	1,23	46,7	268	29,1									
			1,5	2	90L-4	1410	1,41	56,8	237	23,9									
25	24,81	1,5	2	90L-4	1410	2,03	67,2	200	20,2										
20	20,99	1,5	2	90L-4	1410	1,60	67,4	253	25,5										
		1,9	2,6	90LB-4	1415	1,24	67,4	120	12,1										
		0,75	1	80B-4	1400	1,32	57,1	176	17,8										
25	24,5	1,1	1,5	80C-4	1400	1,32	57,1	176	17,8										
20	19,95	1,1	1,5	90S-4	1400	1,32	57,1	176	17,8										
		1,5	2	90L-4	1410	1,41	70,7	195	19,6										
		1,9	2,6	90LB-4	1415	1,46	89,8	194	19,6										
15	15,75	1,9	2,6	90LB-4	1415	1,67	111,6	156	15,7										
13	12,68	1,9	2,6	90LB-4	1415	1,74	135,8	128	12,9										
10	10,42	1,9	2,6	90LB-4	1415	2,37	206,9	84	8,5										
7	6,84	1,9	2,6	90LB-4	1415	2,44	290,0	60	6,1										
5	4,88	1,9	2,6	90LB-4	1415	2,88	353,8	49	5,0										
4	4	1,9	2,6	90LB-4	1415														
30	120	120,2	0,25	0,35	80B-8	690	1,31	5,7	391	39,4									
			0,37	0,5	80A-6	930	1,25	7,7	429	43,3									
			0,37	0,5	71B-4	1400	1,79	11,6	285	28,8									
	110	106,3	0,55	0,75	80A-4	1400	1,20	11,6	424	42,8									
			0,25	0,35	80B-8	690	1,31	6,5	346	34,9									
			0,37	0,5	80A-6	930	1,25	8,7	380	38,3									
	100	102,47	0,37	0,5	71B-4	1400	1,79	13,2	252	25,4									
			0,55	0,75	80A-4	1400	1,20	13,2	375	37,8									
			0,75	1	80B-4	1400	1,44	15,3	322	32,5									
	90	91,24	0,75	1	80B-4	1400	1,06	15,3	439	44,3									
	80	84,26	0,55	0,75	80A-4	1400	1,56	16,6	297	30,0									
			0,75	1	80B-4	1400	1,15	16,6	405	40,9									
			0,75	1	80B-4	1400	1,41	19,4	348	35,1									
	70	72,29	0,75	1	80B-4	1400	1,94	23,3	289	29,2									
	60	60,16	1,1	1,5	90S-4	1400	1,32	23,3	424	42,8									
			1,1	1,5	90S-4	1400	1,44	25,2	392	39,5									
			1,5	2	90L-4	1410	1,06	25,4	531	53,5									
	50	49,45	1,1	1,5	90S-4	1400	1,20	28,3	349	35,2									
	45	47,66	1,1	1,5	90S-4	1400	1,68	29,4	336	33,9									
			1,5	2	90L-4	1410	1,23	29,6	455	45,9									
			1,5	2	90L-4	1410	1,59	35,9	375	37,8									
	40	39,26	1,9	2,6	90LB-4	1415	1,25	36,0	473	47,7									
	35	35,46	1,5	2	90L-4	1410	1,68	39,8	339	34,2									
			1,9	2,6	90LB-4	1415	1,32	39,9	427	43,1									
			1,5	2	90L-4	1410	1,85	46,3	291	29,3									
	30	30,44	1,9	2,6	90LB-4	1415	1,46	46,5	367	37,0									
	25	25,38	1,9	2,6	90LB-4	1415	1,74	55,8	306	30,9									
			2,2	3	100LA-4	1420	1,50	55,9	353	35,6									
			3	4	100LB-4	1420	1,10	55,9	481	48,6									
	20	22,3	2,2	3	100LA-4	1420	1,98	63,7	310	31,3									
3			4	100LB-4	1420	1,46	63,7	423	42,7										
4			5,5	112M-4	1420	1,09	63,7	564	56,9										
23	23,02	1,5	2	90L-4	1410	1,50	61,3	225	22,7										
		1,9	2,6	90LB-4	1415	1,18	61,5	283	28,6										
		1,5	2	90L-4	1410	1,59	69,3	199	20,0										
20	20,36	1,9	2,6	90LB-4	1415	1,25	69,5	251	25,3										
18	18,37	1,5	2	90L-4	1410	1,76	76,8	179	18,1										
		1,9	2,6	90LB-4	1415	1,39	77,0	226	22,8										
		2,2	3	100LA-4	1420	1,20	77,3	261	26,3										
15	14,27	2,2	3	100LA-4	1420	1,80	99,5	203	20,4										
		3	4	100LB-4	1420	1,32	99,5	276	27,9										
		4	5,5	112M-4	1420	0,99	99,5	369	37,2										

PERFORMANCE TABLE 30-35-40



rpm n_1 = 1450

ROBUS	rated ratio i:	real ratio i:	input power P_{n1}				fs	output P_{n2}			stages	input connection B5 IEC 72-1								
			kW	Hp	motore	n_1 [rpm]		n_2 [rpm]	M_2 [Nm]	M_2 [Kgm]		63	71	80	90	100/112	132	160	180	
30	10	9.96	4	5.5	112M-4	1420	1.85	142.6	257	26.0										
	7	6.79	5	6.8	112MB-4	1450	1.32	145.6	315	31.8										
	5	5.66	5	6.8	112MB-4	1450	1.77	213.5	215	21.7										
	4	4.05	5	6.8	112MB-4	1450	1.85	256.2	179	18.1										
35	120	123.2	0.25	0.35	80B-8	690	1.46	5.6	401	40.4										
			0.37	0.5	80A-6	930	1.40	7.5	440	44.4										
			0.37	0.5	71B-4	1400	2.00	11.4	292	29.5										
			0.55	0.75	80A-4	1400	1.35	11.4	434	43.8										
			0.75	1	80B-4	1400	0.99	11.4	592	59.8										
			0.25	0.35	80B-8	690	1.70	6.5	343	34.7										
	110	105.6	0.37	0.5	80A-6	930	1.62	8.8	377	38.1										
			0.55	0.75	80A-4	1400	1.56	13.3	372	37.6										
			0.75	1	80B-4	1400	1.15	13.3	508	51.2										
			0.75	1	80B-4	1400	1.41	14.2	475	47.9										
			1.1	1.5	80C-4	1390	0.96	14.1	702	70.8										
			0.75	1	80B-4	1400	1.76	16.5	407	41.1										
	90	84.7	1.1	1.5	90S-4	1400	1.20	16.5	597	60.3										
			0.75	1	80B-4	1400	1.94	17.5	384	38.7										
			1.1	1.5	90S-4	1400	1.32	17.5	563	56.8										
			1.5	2	90L-4	1410	0.97	17.7	763	76.9										
			1.1	1.5	90S-4	1400	1.44	20.5	483	48.7										
			1.5	2	90L-4	1410	1.06	20.6	654	65.9										
	60	59.29	1.5	2	90L-4	1410	1.59	23.8	566	57.1										
			1.5	2	90LB-4	1410	1.25	23.9	715	72.1										
			2	2.6	100LA-4	1420	1.08	24.0	825	83.2										
			2	2.6	90L-4	1410	1.32	25.4	591	59.6										
			1.5	2	90L-4	1415	1.04	25.4	670	67.6										
			1.9	2.6	90LB-4	1415	1.46	27.8	613	61.8										
	50	50.82	2	2.6	100LA-4	1420	1.26	27.9	707	71.3										
			1.5	2	90L-4	1410	1.50	30.6	441	44.4										
			1.9	2.6	90LB-4	1415	1.18	30.7	556	56.1										
			2.2	3	100LA-4	1420	1.50	34.4	574	57.9										
			3	4	100LB-4	1420	1.10	34.4	783	79.0										
			2.2	3	100LA-4	1420	1.74	41.5	476	48.1										
	35	34.25	3	4	100LB-4	1420	1.28	41.5	650	65.5										
			3	4	100LB-4	1420	1.54	47.1	572	57.7										
			4	5.5	112M-4	1420	1.16	47.1	763	77.0										
			4	5.5	112M-4	1420	1.42	55.7	645	65.1										
			5	6.8	112MB-4	1450	1.14	56.8	790	79.7										
			4	5.5	112M-4	1420	1.82	72.0	498	50.3										
20	19.71	5	6.8	112MB-4	1450	1.46	73.6	610	61.6											
		5	6.8	112MB-4	1450	1.64	88.7	506	51.0											
		1.9	2.6	90LB-4	1415	2.99	53.6	325	32.8											
		2.2	3	100LA-4	1420	1.92	75.6	267	26.9											
		3	4	100LB-4	1420	1.41	75.6	364	36.7											
		4	5.5	112M-4	1420	1.06	75.6	485	49.0											
15	15.07	3	4	100LB-4	1420	1.98	94.2	292	29.4											
		4	5.5	112M-4	1420	1.49	94.2	389	39.3											
		5	6.8	112MB-4	1450	1.19	96.2	476	48.1											
		4	5.5	112M-4	1420	1.69	113.3	324	32.6											
		5	6.8	112MB-4	1450	1.35	115.7	396	40.0											
		5	6.8	112MB-4	1450	1.69	144.3	318	32.1											
8	7.46	5	6.8	112MB-4	1450	2.04	194.4	236	23.8											
		5	6.8	112MB-4	1450	2.20	277.2	165	16.7											
		4	3.96	5	6.8	112MB-4	1450	2.61	366.2	125	12.6									
		40	120	116.13	0.55	0.75	90L-8	700	1.27	6.0	819	82.6								
					0.75	1	90S-6	915	1.21	7.9	855	86.2								
					0.75	1	80B-4	1400	1.76	12.1	558	56.3								
1.1	1.5				90S-4	1400	1.20	12.1	819	82.6										
0.55	0.75				90L-8	700	1.27	6.6	748	75.4										
0.75	1				90S-6	915	1.21	8.6	780	78.7										
110	105.99	0.75	1	80B-4	1400	1.76	13.2	510	51.4											
		1.1	1.5	90S-4	1400	1.20	13.2	748	75.4											
		0.55	0.75	90L-8	700	1.27	6.9	714	72.0											
		0.75	1	90S-6	915	1.21	9.0	745	75.2											
		0.75	1	80B-4	1400	1.76	13.8	487	49.1											
		1.1	1.5	90S-4	1400	1.20	13.8	714	72.0											
90	92.4	1.1	1.5	90S-4	1400	1.44	15.2	652	65.8											
		1.5	2	90L-4	1410	1.06	15.3	882	89.0											
		1.1	1.5	90S-4	1400	1.56	17.7	559	56.4											
		1.5	2	90L-4	1410	1.15	17.8	757	76.3											
		1.5	2	90L-4	1410	1.50	19.9	675	68.2											
		1.9	2.6	90LB-4	1415	1.18	20.0	853	86.0											
60	63.05	1.9	2.6	90LB-4	1415	1.39	22.4	760	76.7											
		2.2	3	100LA-4	1420	1.20	22.5	877	88.5											
		2.2	3	100LA-4	1420	1.56	26.8	736	74.3											
		3	4	100LB-4	1420	1.15	26.8	1004	101.3											
		2.2	3	100LA-4	1420	1.68	28.3	699	70.5											
		3	4	100LB-4	1420	1.23	28.3	953	96.2											

PERFORMANCE TABLE 40-50



rpm n ₁ =1450		rated ratio i:	real ratio i:	input power P _{n1}				fs	output P _{n2}			stages	input connection B5 IEC 72-1						
ROBUS	kW			Hp	motore	n ₁ [rpm]	n ₂ [rpm]		M _e [Nm]	M _e [Kgm]	63		71	80	90	100/112	132	160	180
40	45	44.46	3	4	100LB-4	1420	1.37	31.9	843	85.1									
			4	4	100LB-4	1420	1.41	34.8	774	78.1									
	35	33.98	3	4	100LB-4	1420	1.54	41.8	644	65.0									
			4	5.5	112M-4	1420	1.16	41.8	859	86.7									
	30	31.94	3	4	100LB-4	1420	1.68	44.5	606	61.1									
			4	5.5	112M-4	1420	1.26	44.5	808	81.5									
			5	6.8	112MB-4	1450	1.01	45.4	989	99.8									
	25	25.97	4	5.5	112M-4	1420	1.72	54.7	657	66.3									
			5.5	7.5	132S-4	1450	1.25	55.8	884	89.2									
	20	20.33	5.5	7.5	132S-4	1450	1.44	71.3	692	69.8									
			7.5	10	132M-4	1450	1.06	71.3	944	95.2									
	15	14.95	7.5	10	132M-4	1450	1.32	97.0	694	70.0									
			9.2	12.5	132MB-4	1450	1.08	97.0	852	85.9									
	25	24.05	2.2	3	100LA-4	1420	1.80	59.0	342	34.5									
			3	4	100LB-4	1420	1.32	59.0	466	47.0									
	23	23.31	3	4	100LB-4	1420	1.76	60.9	451	45.6									
			4	5.5	112M-4	1420	1.32	60.9	602	60.7									
			5	6.8	112MB-4	1450	1.06	62.2	737	74.3									
	20	21.27	4	5.5	112M-4	1420	1.49	66.8	549	55.4									
			5	6.8	112MB-4	1450	1.19	68.2	672	67.8									
	15	14.83	5	6.8	112MB-4	1450	1.61	97.8	469	47.3									
			5.5	7.5	132S-4	1450	1.27	107.1	471	47.5									
	13	13.54	7.5	10	132M-4	1450	1.27	107.1	642	64.8									
			9.2	12.5	132MB-4	1450	1.04	107.1	788	79.5									
10	9.96	7.5	10	132M-4	1450	1.53	145.6	472	47.7										
		9.2	12.5	132MB-4	1450	1.25	145.6	579	58.5										
7	6.65	11	15	132MC-4	1460	1.05	146.6	688	69.4										
		7.5	10	132M-4	1450	1.05	218.0	315	31.8										
5	4.78	9.2	12.5	132MB-4	1450	1.29	218.0	387	39.0										
		11	15	132MC-4	1460	1.08	218.5	459	46.3										
4	4.03	9.2	12.5	132MB-4	1450	1.37	303.3	278	28.1										
		11	15	132MC-4	1460	1.14	305.4	330	33.3										
50	120	117.17	1.5	2	112M-8	710	1.33	6.1	2222	224.2									
			2.2	3	112M-6	950	1.27	8.1	2436	245.8									
			3	4	100LA-4	1420	1.80	12.1	1630	164.4									
			4	5.5	112M-4	1420	1.32	12.1	2222	224.2									
	110	107.2	1.5	2	112M-8	710	1.33	6.6	2033	205.1									
			2.2	3	112M-6	950	1.27	8.9	2229	224.8									
			3	4	100LA-4	1420	1.80	13.2	1491	150.4									
			4	5.5	112M-4	1420	1.32	13.2	2033	205.1									
	100	100.7	1.5	2	112M-8	710	1.33	7.1	1910	192.7									
			2.2	3	112M-6	950	1.27	9.4	2093	211.2									
			3	4	100LA-4	1420	1.80	14.1	1401	141.3									
			4	5.5	112M-4	1420	1.32	14.1	1910	192.7									
	90	92.13	1.5	2	112M-8	710	1.55	7.7	1747	175.3									
			2.2	3	112M-6	950	1.48	10.3	1915	193.2									
			3	4	100LB-4	1420	1.54	15.4	1747	175.3									
			4	5.5	112M-4	1420	1.16	15.4	2330	235.1									
	80	80.06	4	5.5	112M-4	1420	1.65	17.7	2025	204.3									
			5	6.8	112MB-4	1450	1.32	18.1	2478	250.0									
			5.5	7.5	132S-4	1450	1.20	18.1	2726	275.0									
			4	5.5	112M-4	1420	1.65	19.7	1824	184.0									
	70	72.13	5	6.8	112MB-4	1450	1.32	20.1	2233	225.3									
			5.5	7.5	132S-4	1450	1.20	20.1	2456	247.8									
			4	5.5	112M-4	1420	1.82	22.9	1568	158.2									
			5	6.8	112MB-4	1450	1.46	23.4	1919	193.6									
60	61.99	5.5	7.5	132S-4	1450	1.32	23.4	2111	213.0										
		4	5.5	112M-4	1420	1.72	24.6	1460	147.3										
		5	6.8	112MB-4	1450	1.38	25.1	1787	180.3										
		5.5	7.5	132S-4	1450	1.25	25.1	1966	198.4										
55	57.74	4	5.5	112M-4	1420	1.75	28.2	1273	128.5										
		5	6.8	112MB-4	1450	1.40	28.8	1559	157.3										
		5.5	7.5	132S-4	1450	1.27	28.8	1714	173.0										
		5.5	7.5	132S-4	1450	1.49	32.1	1536	155.0										
45	45.12	7.5	10	132M-4	1450	1.09	32.1	2095	211.4										
		5.5	7.5	132S-4	1450	1.54	37.4	1320	133.2										
40	38.78	7.5	10	132M-4	1450	1.13	37.4	1801	181.7										
		7.5	10	132M-4	1450	1.50	42.1	1601	161.5										
35	34.47	9.2	12.5	132MB-4	1450	1.22	42.1	1963	198.1										
		11	15	132MC-4	1460	1.02	42.4	2331	235.2										
30	29.9	7.5	10	132M-4	1450	1.55	48.5	1388	140.1										
		9.2	12.5	132MB-4	1450	1.27	48.5	1703	171.8										
25	27.5	11	15	132MC-4	1460	1.06	48.8	2022	204.0										
		9.2	12.5	132MB-4	1450	1.53	52.7	1277	128.8										
			11	15	132MC-4	1460	1.25	52.7	1566	158.0									
						1.05	53.1	1860	187.7										

PERFORMANCE TABLE 50-60



rpm n₁=1450

ROBUS	rated ratio i:	real ratio i:	input power P _{n1}				fs	output P _{n2}			stages	input connection B5 IEC 72-1						
			kW	Hp	motore	n ₁ [rpm]		n ₂ [rpm]	M _e [Nm]	M _e [Kgm]		63	71	80	90	100/112	132	160
50	20	21.56	11	15	132MC-4	1460	1.60	67.7	1458	147.1	3							
	23	22.83	4	5.5	112M-4	1420	1.49	62.2	590	59.5	2							
			5	6.8	112MB-4	1450	1.19	63.5	722	72.8	2							
			5.5	7.5	132S-4	1450	1.68	73.1	690	69.6	2							
	20	19.83	7.5	10	132M-4	1450	1.23	73.1	940	94.9	2							
			9.2	12.5	132MB-4	1450	1.01	73.1	1153	116.4	2							
			5.5	7.5	132S-4	1450	1.88	79.9	631	63.7	2							
	18	18.15	7.5	10	132M-4	1450	1.38	79.9	861	86.8	2							
			9.2	12.5	132MB-4	1450	1.12	79.9	1056	106.5	2							
			11	15	160M-4	1460	1.46	95.5	1056	106.6	2							
	15	15.29	15	20	160L-4	1460	1.07	95.5	1440	145.3	2							
			15	20	160L-4	1460	1.83	140.8	977	98.5	2							
			18.5	25	180M-4	1470	1.48	141.8	1196	120.7	2							
10	10.37	22	30	180L-4	1470	1.24	141.8	1423	143.6	2								
		18.5	25	180M-4	1470	1.50	183.1	926	93.5	2								
		22	30	180L-4	1470	1.26	183.1	1102	111.2	2								
8	8.03	18.5	25	180M-4	1470	1.70	292.8	579	58.4	2								
		22	30	180L-4	1470	1.43	292.8	689	69.5	2								
		22	30	180L-4	1470	1.73	362.1	557	56.2	2								
5	5.02	22	30	180L-4	1470	1.43	292.8	689	69.5	2								
4	4.06	22	30	180L-4	1470	1.73	362.1	557	56.2	2								
60	120	115.43	3	4.0	132M-8	720	1.24	6.2	4318	435.6	3							
			4	5.5	132MA-6	970	1.19	8.4	4273	431.1	3							
			4	5.5	112M-4	1420	1.65	12.3	2619	294.5	3							
	110	111.72	5.5	7.5	132S-4	1450	1.20	12.6	3930	395.6	3							
			4	5.5	132MA-6	970	1.19	8.7	4136	417.9	3							
			4	5.5	112M-4	1420	1.65	12.7	2825	285.0	3							
	100	101.79	5.5	7.5	132S-4	1450	1.20	13.0	3804	383.8	3							
			3	4.0	132M-8	720	1.24	7.1	3807	384.1	3							
			4	5.5	132MA-6	970	1.19	9.5	3768	380.2	3							
	90	89.28	4	5.5	112M-4	1420	1.65	14.0	2574	259.7	3							
			5.5	7.5	132S-4	1450	1.20	14.2	3466	349.7	3							
			5.5	7.5	132S-4	1450	1.65	15.9	2258	227.8	3							
	80	81.51	5.5	7.5	132S-4	1450	1.20	16.2	3040	306.7	3							
			5.5	7.5	132S-4	1450	1.80	17.8	2775	280.0	3							
			7.5	10	132M-4	1450	1.32	17.8	3785	381.9	3							
	70	69.95	9.2	12.5	132MB-4	1450	1.08	17.8	4643	468.4	3							
			5.5	7.5	132S-4	1450	1.80	20.7	2382	240.3	3							
			7.5	10	132M-4	1450	1.32	20.7	3248	327.7	3							
	60	60.82	9.2	12.5	132MB-4	1450	1.08	20.7	3984	402.0	3							
			5.5	7.5	132S-4	1450	1.80	23.8	2071	208.9	3							
			7.5	10	132M-4	1450	1.32	23.8	2824	284.9	3							
	55	55.42	9.2	12.5	132MB-4	1450	1.08	23.8	3464	349.5	3							
			7.5	10	132M-4	1450	1.76	26.2	2573	259.6	3							
			9.2	12.5	132MB-4	1450	1.44	26.2	3157	318.5	3							
	50	48.03	11	15	160M-4	1460	1.20	26.3	3748	378.2	3							
			9.2	12.5	132MB-4	1450	1.62	30.2	2736	276.0	3							
			11	15	160M-4	1460	1.36	30.4	3249	327.7	3							
	45	44.72	15	20	160L-4	1460	1.00	30.4	4430	446.9	3							
			11	15	160M-4	1460	1.48	32.6	3025	305.2	3							
			15	20	160L-4	1460	1.08	32.6	4125	416.1	3							
	40	38.36	11	15	160M-4	1460	1.80	38.1	2594	261.8	3							
			15	20	160L-4	1460	1.32	38.1	3538	356.9	3							
			18.5	25	180M-4	1470	1.07	38.3	4334	437.2	3							
	35	35.72	11	15	160M-4	1460	1.90	40.9	2416	243.7	3							
			15	20	160L-4	1460	1.39	40.9	3294	332.4	3							
			18.5	25	180M-4	1470	1.13	41.2	4035	407.2	3							
	30	28.33	18.5	25	180M-4	1470	1.59	51.9	3201	322.9	3							
			22	30	180L-4	1470	1.34	51.9	3806	384.0	3							
			18.5	25	180M-4	1470	1.68	59.7	2783	280.7	3							
	25	24.63	22	30	180L-4	1470	1.41	59.7	3309	333.9	3							
			22	30	180L-4	1470	1.98	74.7	2645	266.9	3							
			15	20	160L-4	1470	2.10	96.0	2058	207.7	3							
	23	22.96	5.5	7.5	132S-4	1450	1.54	63.2	798	80.6	2							
			7.5	10	132M-4	1450	1.13	63.2	1089	109.8	2							
			5.5	7.5	132S-4	1450	1.71	69.3	727	73.4	2							
	20	20.92	7.5	10	132M-4	1450	1.25	69.3	992	100.1	2							
			11	15	160M-4	1460	1.44	86.6	794	80.1	2							
			11	15	160M-4	1460	1.06	87.2	1157	116.7	2							
	17	16.75	15	20	160L-4	1460	1.06	87.2	1157	116.7	2							
			11	15	160M-4	1460	1.80	106	672	67.8	2							
			11	15	160M-4	1460	1.80	95.7	1054	106.3	2							
	15	15.26	15	20	160L-4	1460	1.80	95.7	1054	106.3	2							
			18.5	25	180M-4	1470	1.07	96.3	1437	145.0	2							
18.5			25	180M-4	1470	1.54	109.9	1761	177.6	2								
13	13.38	22	30	180L-4	1470	1.29	109.9	1544	155.8	2								
		18.5	25	180M-4	1470	2.47	150.9	1124	113.4	2								
		22	30	180L-4	1470	2.07	150.9	1336	134.8	2								
10	9.74	18.5	25	180M-4	1470	2.57	200.3	847	85.4	2								
		22	30	180L-4	1470	2.16	200.3	1007	101.6	2								
		18.5	25	180M-4	1470	2.65	271.2	625	63.1	2								
7	7.34	22	30	180L-4	1470	2.23	271.2	744	75.0	2								
		18.5	25	180M-4	1470	3.51	367.5	462	46.6	2								
		22	30	180L-4	1470	2.95	367.5	549	55.4	2								

WEIGHTS



input	
63 B14	
71 B14	
80B14	
63/71 B5	
80/90 B5	
100/112 B5	
132 B5	
160 B5	
180 B5	
63 B14	
71 B14	
80 B14	
63/71 B5	
80/90 B5	
100/112 B5	
132 B5	
160 B5	
180 B5	
63 B14	
71B14	
80 B14	
63/71 B5	
80/90 B5	
100/112 B5	
132 B5	
160 B5	
180 B5	
120 56B5	
160 71B5	
200 80/90B5	
250 100/112B5	
300 132B5	
350 160/180B5	
450 200B5	

UNV



FSW



FBF



Weights including oil in Kg															
		ROBUS20		ROBUS25		ROBUS30		ROBUS35		ROBUS40		ROBUS50		ROBUS60	
		2	3	2	3	2	3	2	3	2	3	2	3	2	3
63 B14	UNV	7,3	7,7	-	-	-	-	-	-	-	-	-	-	-	-
71 B14	UNV	7,5	7,9	-	-	-	-	-	-	-	-	-	-	-	-
80B14	UNV	8,8	9,0	-	-	-	-	-	-	-	-	-	-	-	-
63/71 B5	UNV	-	-	12,8	13,4	22,2	23,4	32,0	33,5	-	-	-	-	-	-
80/90 B5	UNV	-	-	13,7	14,3	23,4	24,2	32,5	34,2	39,4	41,7	74,0	78,6	-	-
100/112 B5	UNV	-	-	-	-	24,7	25,7	34,2	35,7	40,9	43,1	75,1	82,9	135,8	141,2
132 B5	UNV	-	-	-	-	-	-	-	-	47,3	49,6	87,5	92,0	136,9	142,3
160 B5	UNV	-	-	-	-	-	-	-	-	-	-	89,9	-	139,3	144,3
180 B5	UNV	-	-	-	-	-	-	-	-	-	-	-	-	139,0	144,4
63 B14	FSW	8,8	9,2	-	-	-	-	-	-	-	-	-	-	-	-
71 B14	FSW	9,0	9,4	-	-	-	-	-	-	-	-	-	-	-	-
80 B14	FSW	10,3	10,5	-	-	-	-	-	-	-	-	-	-	-	-
63/71 B5	FSW	-	-	14,7	15,3	25,8	27,0	37,2	38,7	-	-	-	-	-	-
80/90 B5	FSW	-	-	15,6	16,2	27,0	27,8	37,7	39,4	45,9	48,2	88,0	92,6	-	-
100/112 B5	FSW	-	-	-	-	28,3	29,3	39,4	40,9	47,4	49,6	89,1	96,9	164,8	170,2
132 B5	FSW	-	-	-	-	-	-	-	-	53,8	56,1	101,5	106,0	165,9	171,3
160 B5	FSW	-	-	-	-	-	-	-	-	-	-	103,9	-	168,3	173,3
180 B5	FSW	-	-	-	-	-	-	-	-	-	-	-	-	168,0	173,4
63 B14	FBF	8,9	9,3	-	-	-	-	-	-	-	-	-	-	-	-
71B14	FBF	9,1	9,5	-	-	-	-	-	-	-	-	-	-	-	-
80 B14	FBF	10,4	10,6	-	-	-	-	-	-	-	-	-	-	-	-
63/71 B5	FBF	-	-	15,6	16,2	26,6	27,8	39,5	41,0	-	-	-	-	-	-
80/90 B5	FBF	-	-	16,4	17,1	27,8	28,6	40,0	41,7	49,7	52,0	95,7	100,3	-	-
100/112 B5	FBF	-	-	-	-	29,1	30,1	41,7	43,2	51,2	53,4	96,8	104,6	162,2	167,6
132 B5	FBF	-	-	-	-	-	-	-	-	57,6	59,9	109,2	113,7	163,3	168,7
160 B5	FBF	-	-	-	-	-	-	-	-	-	-	111,6	-	165,7	170,7
180 B5	FBF	-	-	-	-	-	-	-	-	-	-	-	-	165,4	170,8

=UNV+0,4															
	=UNV+0,9														
	=UNV+1,7	=UNV+0,9		=UNV+0,9											
				=UNV+1,7				=UNV+1,8							
								=UNV+3,8							
									=UNV+4,1						
									=UNV+7,2						
										=UNV+5,8					
										=UNV+9,8					
											=UNV+8,9				
												=UNV+19,9			

DIMENSIONS

ROBUS	motor type		Nm	Mm	Pm	Sm	Dm	tm	bm	L
25	63	B5	95	115	140	M8	11	12,8	4	273,0
	71	B5	110	130	160		14	16,3	5	
	80	B5	130	165	200	M10	19	21,8	6	
	90	B5					24	27,3	8	
30	63	B5	95	115	140	M8	11	12,8	4	317,6
	71	B5	110	130	160		14	16,3	5	
	80	B5	130	165	200	M10	19	21,8	6	
	90	B5					24	27,3	8	
	100/112	B5	180	215	250	M12	28	31,3	8	
35	63	B5	95	115	140	M8	11	12,8	4	357,0
	71	B5	110	130	160		14	16,3	5	
	80	B5	130	165	200	M10	19	21,8	6	
	90	B5					24	27,3	8	
	100/112	B5	180	215	250	M12	28	31,3	8	
40	80	B5	130	165	200	M10	19	21,8	6	396,5
	90	B5					24	27,3	8	
	100/112	B5	180	215	250	M12	28	31,3	8	
	132	B5	230	265	300		38	41,3	12	
50	90	B5	130	165	200	M10	24	27,3	8	447,0
	100/112	B5	180	215	250	M12	28	31,3	8	450,0
	132	B5	230	265	300		38	41,3	12	
	160	B5	250	300	350	M16	42	45,3	12	
60	100/112	B5	180	215	250	M12	28	31,3	8	567,4
	132	B5	230	265	300		38	41,3	12	
	160	B5	250	300	350	M16	42	45,3	12	585,6
	180	B5					48	51,8	14	

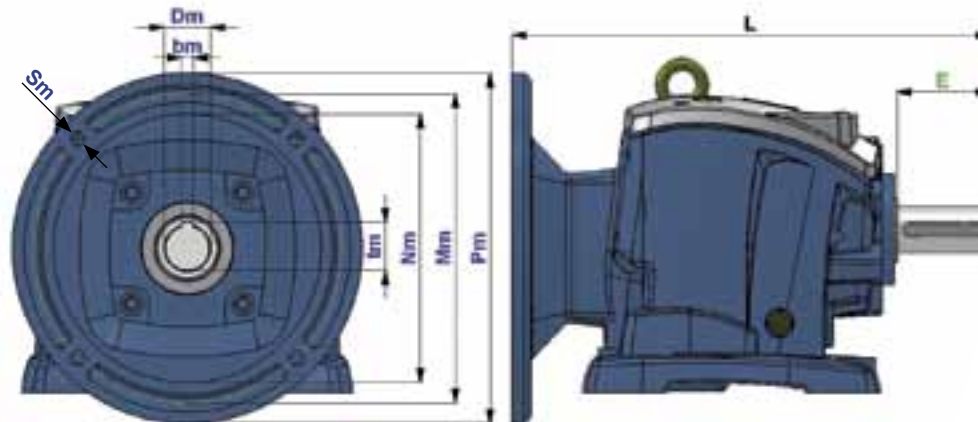

DIMENSIONS

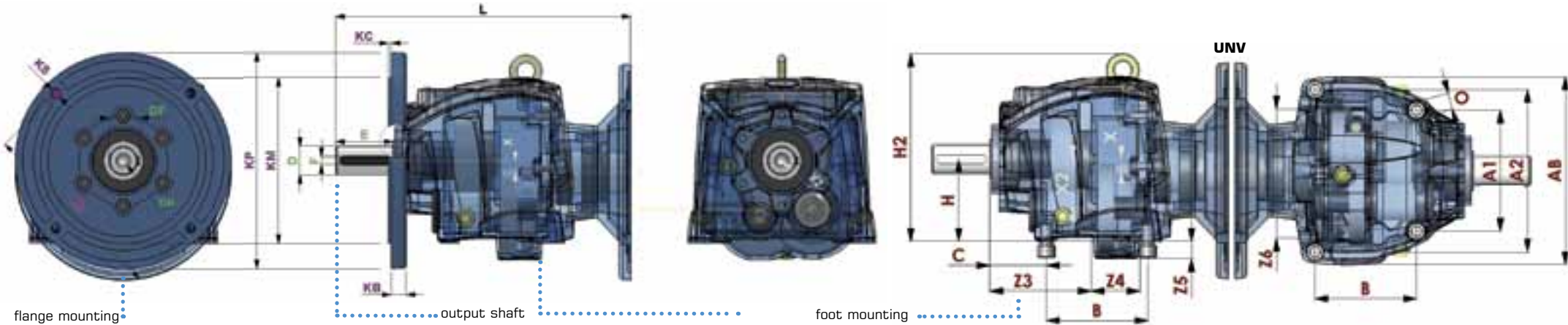

flange mounting

output shaft

foot mounting

ROBUS	IEC	KP	KM	KN	KS	KC	KB	D	E	F	DF	DH	X	X2	type	B	BA	A	AB	O	H	H2	C	Z3	Z4	Z5	Z6
25	80/90B5	200	130	165	11	3,5	12	25 (k6)	50	8	28	M10x20L	11	52,5	SW	130	171,5	110	145	9	90	193,6	25	-	-	-	-
	71B5	160	110	130	9	3,5	10							BF	107,5	173,8	130	180,5	9	100	203,5	18	-	-	-	-	
30	80/90B5	200	130	165	11	3,5	12	30 (k6)	60	8	33	M10x20L	13,5	66	UNV	90,6	-	A1=108 A2=145	170	M10	73,5	180	54,5	95	84	17	128
	71B5	160	110	130	9	3,5	10							SW	165	209	135	233	14	115	238,6	30	-	-	-	-	
35	100/112B5	250	180	215	13,5	4	15	35 (k6)	70	10	38	M12x24L	17	72	BF	130	213,5	160	229	14	120	243,5	18	-	-	-	-
	80/90B5	200	130	165	11	4	12							UNV	115,8	-	A1=138 A2=186	215	M12	94	215	62,4	115	95	22	155	
40	132B5	300	230	265	14	4	21	40 (k6)	80	12	43	M16x32	16	80	SW	195	236,7	150	263,7	14	130	264	30	-	-	-	-
	100/112B5	250	180	215	14	4	19							BF	149,5	246,8	180	269	14	140	274,5	19,5	-	-	-	-	
50	160/180B5	350	250	300	18	5	21	50 (k6)	100	14	53,5	M16x32	18	103	UNV	131	-	A1=156 A2=210	243	M12	106	235	74	135	105	20	168
	132B5	300	230	265	14	4	19							SW	205	255	170	283,7	18	140	287	35	-	-	-	-	
60	225B5	450	350	400	18	5	25	60 (m6)	120	18	64	M20x40	20	120	BF	156	266	225	290	18	155	302	25	-	-	-	-
	160/180B5	350	250	300	18	5	21							UNV	141	-	A1=168 A2=226	262	M16	114	262	78,5	140	65	27	190	
														SW	260	327,7	215	364,6	18	180	357	40	-	-	-	-	
														BF	180	336	250	372,5	18	195	372	25	-	-	-	-	
														UNV	181,3	-	A1=216 A2=291	336	M16	148	313	92	170	98	32	250	
														SW	310	393	250	438	22	225	428	40	-	-	-	-	
														BF	165	394	300	437,5	22	217	421	25	-	-	-	-	
														UNV	217,6	-	A1=259 A2=349	405	M16	176	381	103	185	120	43	295	

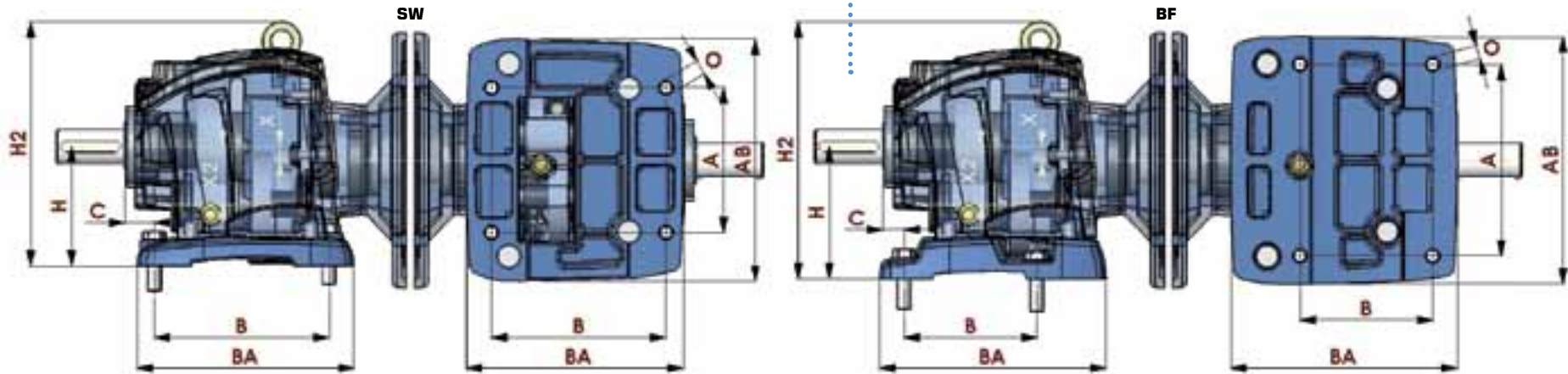

TERMS OF SALE AND GUARANTEE

ARTICLE 1 GUARANTEE

1.1 Barring written agreements, entered into between the parties hereto each time, Motive hereby guarantees compliance with specific agreements.

The guarantee for defects shall be restricted to product defects following design, materials or manufacturing defects leading back to Motive.

The guarantee shall not include:

- * Faults or damages ensuing from transport. Faults or damages ensuing from installation defects; incompetent use of the product, or any other unsuitable use.
- * Tampering or damages ensuing from use by non-authorized staff and/or use of non-original parts and/or spare parts;
- * Defects and/or damages ensuing from chemical agents and/or atmospheric phenomena (e.g. burnt out material, etc.); routine maintenance and required action or checks;
- * Products lacking a plate or having a tempered plate.

1.2 Returns to credit or replace will be accepted only in exceptional cases; however returns of goods already used to credit or replace won't be accepted in any case.

The guarantee shall be effective for all Motive products, with a term of validity of 12 months, starting from the date of shipment.

The guarantee shall be subject to specific written request for Motive to take action, according to statements, as described at

the paragraphs herein below. By virtue of aforesaid approval, and as regards the claim, Motive shall be bound at its discretion, and within a reasonable time-limit, to alternatively take the following actions:

- a) To supply the Buyer with products of the same type and quality as those having proven defective and not complying with agreements, free ex-works; in aforesaid case, Motive shall have the right to request, at Buyer's charge, early return of defective goods, which shall become Motive's property;
- b) To repair, at its charge, the defective product or to modify the product which does not comply with agreements, by performing aforesaid action at its facilities; in aforesaid cases, all costs regarding product transport shall be sustained by the Buyer.
- c) To send spare parts free of charge: all costs regarding product transport shall be sustained by the Buyer.

1.3. The guarantee herein shall assimilate and replace legal guarantees for defects and discrepancies, and shall exclude any other eventual Motive liability, however caused by supplied products; in particular, the Buyer shall have no right to submit any further claims.

Motive shall not be liable for the enforcement of any further claims, as of the date the guarantee's term of validity expires.

ARTICLE 2 CLAIMS

2.1. Claims, regarding quantity, weight, gross weight and colour, or claims regarding faults and defects in quality or compliance, and which the Buyer may discover on goods delivery, shall be submitted by a max. 7 days of aforesaid discovery, under penalty of nullity.

ARTICLE 3 DELIVERY

3.1. Any liability for damages ensuing from total or partial delayed or failed delivery, shall be excluded.

3.2. Unless differently communicated by written to the Client, the transport terms have to be intended ex-works.

ARTICLE 4 PAYMENT

4.1. Any delayed or irregular payments shall entitle Motive to cancel ongoing agreement, including agreements which do not regard the payments at issue, as well as entitling Motive to claim damages, if any. Motive shall, however, have the right, as of payment's due date and without placing in arrears, to claim interest for arrears, to the extent of the discount rate in force in Italy, increased by 12 points. Motive shall also have the right to withhold material under repair for replacement. In the case of failed payment, Motive shall have the right to cancel all guarantees of materials, as regards the insolvent Client.

4.2. The Buyer shall be bound to complete payment, including cases whereby claims or disputes are underway.

ALL DATA HAVE BEEN WRITTEN AND
CHECKED WITH THE
GREATEST CARE.
WE DO NOT TAKE ANY RESPONSIBILITY
FOR POSSIBLE ERRORS OR
OMISSIONS.
MOTIVE CAN CHANGE THE
CHARACTERISTIC OF THE SOLD
ITEMS ON HIS FIRM OPINION AND
IN EVERY MOMENT.





Motive s.r.l.

Via Le Ghiselle, 20

25014 Castenedolo (BS) - Italy

Tel.: +39.030.2677087 - Fax: +39.030.2677125

web site: www.motive.it

e-mail: motive@e-motive.it



AREA DISTRIBUTOR